



BII2160 Series T/R (Transmitting and Receiving) Switch Modules

A BII2160 Series T/R switch module is an integrated solution for a wide range of acoustic applications based on Emitting and Listening Timing Techniques. The device works at active mode (Transmitting Sounds) and passive mode (Listening Sounds) with a transducer which can radiate and receive sounds. A BII2160 device integrates an impedance matching network, a T/R switch, a bandpass filter, and Automatic Gain Control (AGC) amplifier into one compact housing.

Tips: Separation of transmitting element and receiving element below 1MHz can improve receiving performances such as lower noise level, optimum directivity, and higher sensitivity etc. BII manufactures [transducers with separated transmitting elements and receiving elements](#) to achieve better acoustic performances below 1MHz.

Built-in AGC (Automatic Gain Control) Amplifier: 100 dB Automatic Gain Range, 100 Hz to 1 MHz Bandwidth.

An Automatic Gain Control (AGC) amplifier is a dynamic adaptive electronic system whose gain changes automatically with input levels of continuous waveform (CW) or pulsed signals such as SINE pulses, Chirp/FM pulses, BFSK/FSK, etc. Its output signal level is always in detectable range for DAQ modules (A/D Converters) although the input signal levels vary in a wide range. That is, the AGC effectively attenuates the strong input signals to avoid saturation and amplifies weak signal to be in the range of Volt. The AGC amplifier automatically compensate the propagation losses in water, air, and solids.

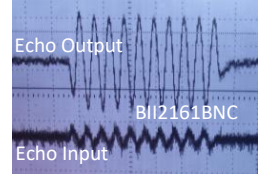

Typical Applications:

Underwater Communication/Pinger/Beacons/Transponder.	Acoustic Modem, BFSK/FSK Signal Conditioning.
Echosounding, Marine Mammal Research, Bioacoustics.	Navigation, Positioning, Acoustic Tag.
Doppler SONAR, Speed Measurement, Artificial Acoustic Target.	Ultrasonic Pulsing System, NDT, AE, Diagnostic Ultrasound, Material Study.

Acoustic Transmitting and Receiving System

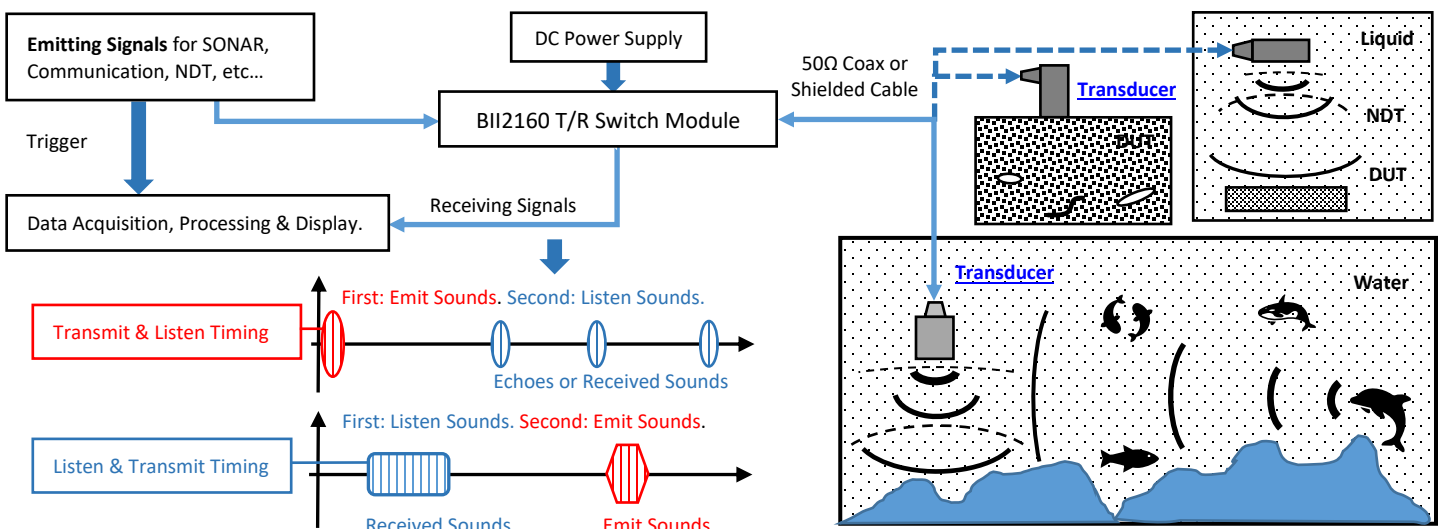
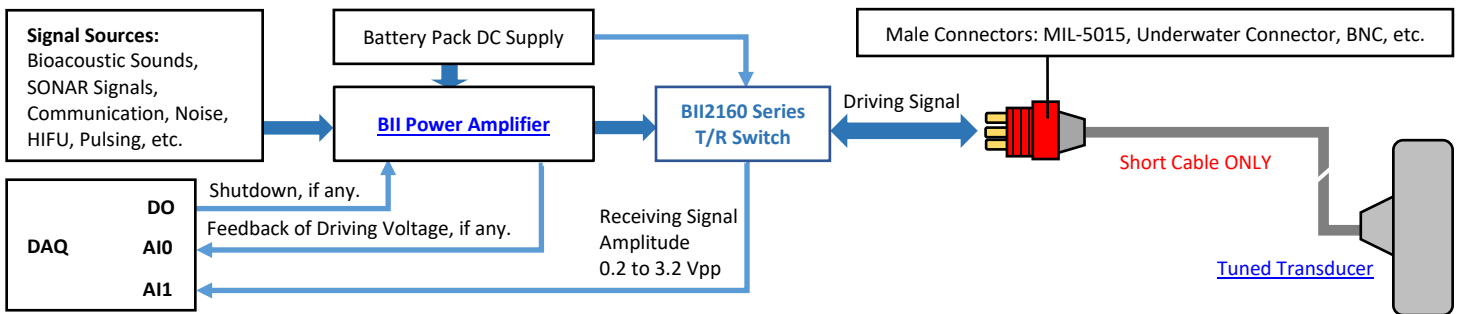
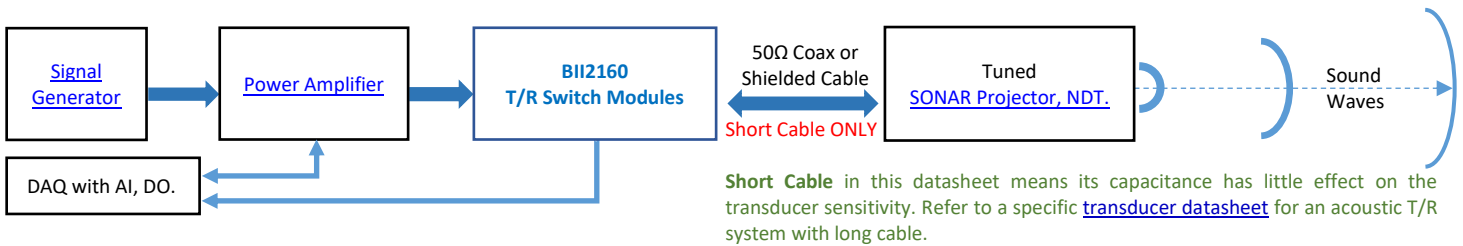

Specifications

PD: Pulse Duration; D: Duty Cycle; V_T: Transmit Voltage; R_{TX}: Resistance of Tuned Transducer; G: Conductance of a Untuned Transducer.		
FG: Fixed Gain; PG: Programmable Gain; DF: Differential Output; SE: Single Ended Output; BPF: Band Pass Filter; HPF: High Pass Filter; LPF: Low Pass Filter.		
Part Number	BII2161MIL	BII2161BNC
	ACTIVE	ACTIVE
	MIL: Panel-Mount MIL-5015 Connectors; BNC: Panel-Mount BNCs.	
	ACTIVE: Product device recommended for new designs. LIFEBUY: BII has announced that the device will be discontinued, and a lifetime-buy period is in effect. OBSELETE: BII has discontinued production of the device.	
Typical Applications:	Standalone	Standalone
	Half-duplex or Semi-duplex Acoustic System: transmitting sounds and receiving sounds at separate timing.	
Echo Sounding Distance:	≥ 1 m, Dependent on the near-field distance, bandwidth, and operating frequency of a transducer.	
Transducers:	Tuned transducers: Reactance is cancelled out. There is pure resistance at operating frequency f_s , and Power Factor = 1.	
	Untuned transducers: There is complex impedance (G-B, R-X, or Z-θ) at operating frequency f_s and Power Factor < 1. Power Factor is corrected to 1 with the impedance matching network in the device.	
	Note: Tuned transducers can achieve much higher acoustic power than untuned transducers.	
DC Supply Fuse:	Panel Mount Fuse: 0.3A, 250VAC, Slow-Blow, 3AB, 3AG, 1/4" x 1-1/4".	
DC Switch:	Turn ON/OFF DC power supply.	
Grounding:	GWL18	
Housing:	Aluminum Housing.	
	Note: BII uses third-party's metal housing in production. Because of variation of suppliers' production, BII reserve the right to use different enclosures whose functions are compatible to the ones listed in this specification.	
Mounting:	Four holes and/or slots for installing the device to a firm base. Refer to the respective drawings for the size. Fasteners (Screws, Washers, Nuts, etc.) for installing or mounting the devices: not included.	
Weight:	0.9 to 1.5 kg	0.8 kg
Size LxWxH (mm):	146.9 x 91.7 x 67	
Operation Temperature:	-10 to +60 °C, or 14 to 140 °F.	
Storage Temperature:	-20 to +60 °C, or -4 to 140 °F.	
Sound Transmitting		
Signal Type:	Pulsing Signals of SONAR, Communication, NDT: Tone Burst (Sinusoidal) Excitation, Chirp Pulse, Square Wave Pulse, Spike (Shock) Pulse, Coded Excitation (Barker/Golay), etc.	
	Continuous Signals, Arbitrary Signals, Aquatic/Marine Animal Sounds, Ambient and Ship/Vehicle Noises, etc.	
f _s Range:	1 kHz ~ 1 MHz.	1 kHz ~ 1 MHz.
	f_s is resonant frequency of a transducer at which maximum TVR exists.	
Operating Range of f _s :	0.5f _s to 1.5f _s .	
	Take an example of f _s =50 kHz specified during ordering, respective TR Switch can work with transducers whose f _s is from 25 to 75kHz.	
Impedance Matching:	Yes, built-in, Impedance matching between Signal Source and Transducer for maximum power delivery.	
Voltage Gain at f _s :	$= 10 * \log_{10}(R_{TX}/R_o)$, in dB. R _{TX} : Resistance of a tuned transducer at f _s .	
	$\approx 10 * \log_{10}(1/(R_oG))$, in dB. R _o : Output Resistance of Signal Source. G: Conductance of a untuned transducer at f _s .	
Transmit Voltage V _T :	Refer to Maximum Peak Pulse Voltage as function of Pulse Duration and Duty Cycle . V _T in Vpp.	
	Warning: Transmit Voltage exceeding Maximum Peak Pulse Voltage destroy the T/R Switch.	
Max. Transmit Current:	10 A _{rms}	1 A _{rms} , continuous. 5 A _{peak} at PD ≤ 10 mS. 10 ~ 20 A _{peak} at PD ≤ 1 μS.
	≤ 2000 W _{RMS}	≤ 100 W _{RMS} , continuous. ≤ 500 W _{RMS} , PD ≤ 10 mS and D ≤ 1%. ≤ 2000 W _{RMS} , PD ≤ 1 μS and D ≤ 1%.
		Warning: Pulse Power exceeding the rating of a TR Switch will damage the device.
SINE Pulse: Average Pulse Power during PD to Tuned Transducer (Resistive Load R _{TX}), P _{avg} = V _T ² /(8R _{TX}). Burst Square Signal: Average Pulse Power during PD to Tuned Transducer (Resistive Load R _{TX}), P _{avg} = V _T ² /(4R _{TX}). Burst Pulse Train: Average Pulse Power during PD to Tuned Transducer (Resistive Load R _{TX}), P _{avg} = V _T ² /(2R _{TX}). SINE Pulse: Average Pulse Input Power to Untuned Transducer (Complex Load), P _{avg} = V _T ² *G/8. Burst Square Signal: Average Pulse Input Power to Untuned Transducer (Complex Load), P _{avg} = V _T ² *G/4. Burst Pulse Train: Average Pulse Input Power to Untuned Transducer (Complex Load), P _{avg} = V _T ² *G/2. Positive or Negative Voltage Spike: Peak Pulse Power during PD to 50Ω Transducer, P _{peak} = V _T ² /50Ω, approximately. Signal Types: Referring to Typical Signals for Active SONAR... in Acoustic Transducers and Measurement Handbook . Warning: Pulse Power exceeding power rating of a transducer will damage the transducer.		
Connector:	Panel-Mount MIL-5015 Type Connector (MIL).	Panel-mount BNC Jack.
Sound Receiving		
Signal Type:	Pulsing Signals of SONAR, Communication, NDT: Tone Burst (Sinusoidal) Excitation, Chirp Pulse, Square Wave Pulse, Spike (Shock) Pulse, Coded Excitation (Barker/Golay), etc.	
	Continuous Signals, Arbitrary Signals, Aquatic/Marine Animal Sounds, Ambient and Ship/Vehicle Noises, etc.	
Minimum Signal Duration:	1 μS. Signals with duration < 10 μS might not be fully amplified by receiving amplifiers resulting in loss of signals in noises.	
Receiving Frequency:	100 Hz to 1 MHz.	100 Hz to 1 MHz.
Receiving Gain:	-20 to 80 dB. Gain is set automatically by the device and depends on frequency and input signal level.	
Gain Vs. Frequency:	Refer to Frequency Response of Receiving Gain . Gain-bandwidth Product = 16 GHz.	
Band Pass Filter: (Default)	Default: 0.1*f _s to 10*f _s .	Default: 0.1*f _s to 10*f _s .
	-3 dB bandwidth of receiving signal processing. Built-in, 2nd order, 40 dB/Decade Roll-off.	
	Note: The narrower the pass band of the filter is, the lower the ambient and electronic noises are.	
Band Pass Filter: (Bespoke)	Built-in, Customized, Specify -3dB cut-off frequency when ordering. Bespoke High Pass Filter HPF ≥ 100 Hz. Bespoke Low Pass Filter LPF ≤ 1 MHz.	

Note: The narrower the pass band of the filter is, the lower the ambient and electronic noises are.	
Filters of Receiving Signals.	
1. Both oceanic ambient noises and the self-noises of electronic devices decrease when frequency increases. It is recommended to choose a built-in high pass filter to reject noises in low frequency range. For example, if you are interested in the signals greater than 30 kHz, you may specify a high pass filter of a preamp with -3dB cut-off frequency 3 kHz to improve signal to noise ratio of the signals of the interest.	
2. The most significant component in received signals dominates AGC function of BII2160 series. That is, if noise inundates useful signals, the noise is being amplified instead of useful signals. Choosing suitable high pass filter is important to reject low frequency noise.	
Input Referred Noise e_n: (at $f \geq 1$ kHz)	13.5 nV/√Hz. 11.5 nV/√Hz.
	Total equivalent pressure noise level at input, P_n in dB $\mu Pa = 20 * LOG_{10}(e_n * \sqrt{BW}) - FFVS - 180$.
	BW: -3dB bandwidth of receiving. FFVS: Free field voltage response of receiving.
Input Dynamic Range:	≥ 90 dB at 10 kHz Bandwidth
Input Range of Receiver:	(-103 +FFVS) to (17 + FFVS).
	For example: A hydrophone has FFVS of -190 dB V/ μPa , detection range = 87 to 207 dB μPa .
Settling Time, 0.01%:	3 μs to 0.1%, Output Step 10 Vpp.
Received Signal	
Output Signal Range:	0.2 to 3.2 Vpp, or -23 to 1.07 dB Vrms.
Output Impedance:	50 Ω
Cable Drive Capability:	200 m, and 50 Ω Coax.
Output Signal:	Waveform, AC Coupled.
Output Signal Type:	Single Ended
Output Connector:	BNC Jack
DC Power Supply	
Supply Voltage V_s:	Default: +16 to +32 VDC
	Bespoke DC Supply Voltage V_s : +30 to +45 VDC. Appending -MV to part number. For example: BII2161BNC-MV.
	Bespoke DC Supply Voltage V_s : +45 to +60 VDC. Appending -HV to part number. For example: BII2161BNC-HV.
Current (Quiescent):	21.3 mA
DC Power Supply Cable:	DCBP24
Suggested DC Supply:	9V Battery, Marine Battery, Automobile Battery, Battery Pack, Subsea Battery, or DC Power Supply with Grounded Output and Protection of Output Current Limit.
<p>WARNING: The buyer observes the National Electrical Code or other related codes of buyer's country to assemble and integrate this device into buyer's product or system, and follow the code to ground and insulate this device. It is buyer's sole responsibility to make sure the proper insulation and grounding for operating safety before putting the device into service.</p> <p>Dangerous voltages, capable of causing injury or death, are present in this device. DO NOT TOUCH THE DEVICE, ITS WIRES, CABLES, AND CONNECTORS BEFORE THE POWER SUPPLIES AND SIGNAL SOURCES ARE SHUT DOWN.</p> <ol style="list-style-type: none"> All exposed bare wires, metal wires, wire leads, and solders shall be insulated with insulation material such as heat shrink tubing, fully insulated wire splicing connectors, etc. The insulation voltage must be greater than twice the maximum voltage of the device. This device MUST be firmly grounded for operation safety. Cable shield, if any, MUST be grounded for operation safety. Coax with BNC is not intended for hand-held use at voltages above 30VAC/60VDC. It is buyer's sole responsibility to make sure that the BNC shield of the signal source is firmly grounded for operation safety before hooking up the device to the signal source. 	

Acoustic Pulse-Echo Systems in a Small-body Water Tank

30 kHz Sine Pulse, System is Based on BII2161BNC.

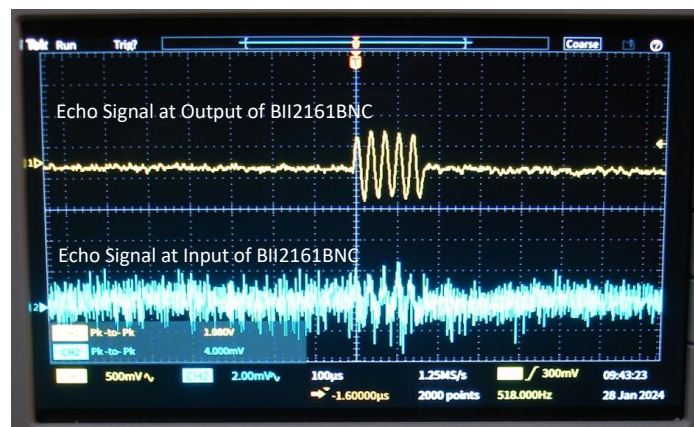

How to Choose BII TR Switch and Transducers (tuned or untuned) according to my acoustic project?

Acoustic Project I: Sub-Bottom Profiling.

Requisites: **Electrical Average Power to Transducer** $P_{avg} = 1000W$ during 1ms pulse duration; **Operating Frequency:** 8 kHz.

Transducer Options: (1) **A untuned transducer** $G_{max} = 0.73mS$, $B = 0.8mS$ at $f_s = 8kHz$.

(2) **A series-tuned transducer** $R_{TX} = 400\Omega$ at $f_s = 8kHz$.

Step 1. **Signal Types.** Referring to [Typical Signals for Active SONAR...](#) in BII's [Acoustic Transducers and Measurement Handbook](#).

Step 2. Refer to [Max. Transmit Current](#), [Pulse Power Capacity during PD](#) and [Maximum Peak Pulse Voltage as function of Pulse Duration and Duty Cycle](#).

BII2161MIL meets limitations above.

Signal Types	Exciting Voltage to Transducer	TR Switch	PD and D
Sine Pulse (SP) to untuned transducer achieving 1000W P_{avg} :	$V_{tx} = \sqrt{8 * P_{avg} / G_{max}} = 3310 V_{pp}$.	None	None
Burst Square Signal (BSS) to untuned transducer achieving 1000W P_{avg} :	$V_{tx} = \sqrt{4 * P_{avg} / G_{max}} = 2341 V_{pp}$.	None	None
Sine Pulse (SP) to series-tuned transducer achieving 1000W P_{avg} :	$V_{tx} = \sqrt{8 * P_{avg} * R_{TX}} = 1789 V_{pp}$.	None	None
Burst Square Signal (BSS) to series-tuned transducer achieving 1000W P_{avg} :	$V_{tx} = \sqrt{4 * P_{avg} * R_{TX}} = 1265 V_{pp}$.	BII2161MIL	PD = 1mS, D ≤ 10%

Step 3. **Determine Receiving Bandwidth.** Operating f is 8kHz. Refer to [Input Referred Noise en](#).

To reduce electronic noise, at same time, to avoid affecting 8kHz echo signal, -3dB bandpass filter of receiving can be set to 0.8 to 80 kHz.

Take BII2161MIL and FFVS = -180.0 dBV/ μPa as an example, equivalent pressure noise level at input from electronics, approximately:

$P_n = -108.4$ dBV – FFVS of the transducer = 71.6 dB μPa .

Acoustic Project II: Underwater Communication.

Requisites: (1) **Electrical Average Power to Spherical Transducer** $P_{avg} = 300W$ during 10ms pulse duration, D=10%;

(2) Transmit and Receive **Communication Carrier Frequency:** 35kHz

Transducer Options: (1) **Untuned spherical transducer** BII7523 $G_{max} = 10.8mS$, $B = 8mS$ at $f_s = 35kHz$.

(2) **Series-tuned spherical transducer** BII7523ST $R_{TX} = 60\Omega$ at $f_s = 35kHz$.

Step 1. **Signal Types.** Referring to [Typical Signals for Active SONAR...](#) in BII's [Acoustic Transducers and Measurement Handbook](#).

Step 2. Refer to [Max. Transmit Current](#), [Pulse Power Capacity during PD](#) and [Maximum Peak Pulse Voltage as function of Pulse Duration and Duty Cycle](#).

Both BII2161MIL and BII2161BNC meet limitations above. But BII2161BNC has lower voltage noise than BII2161MIL.

Signal Types	Exciting Voltage to Transducer	TR Switch	PD and D
Sine Pulse (SP) to untuned transducer achieving 300W P_{avg} :	$V_{tx} = \sqrt{8 * P_{avg} / G_{max}} = 471.4 V_{pp}$.	BII2161MIL, BII2161BNC.	PD = 10mS, D = 10%.
Burst Square Signal (BSS) to untuned transducer achieving 300W P_{avg} :	$V_{tx} = \sqrt{4 * P_{avg} / G_{max}} = 333.4 V_{pp}$.	BII2161MIL, BII2161BNC.	PD = 10mS, D = 10%.
Sine Pulse (SP) to series-tuned transducer achieving 300W P_{avg} :	$V_{tx} = \sqrt{8 * P_{avg} * R_{TX}} = 379.5 V_{pp}$.	BII2161MIL, BII2161BNC.	PD = 10mS, D = 10%.
Burst Square Signal (BSS) to series-tuned transducer achieving 300W P_{avg} :	$V_{tx} = \sqrt{4 * P_{avg} * R_{TX}} = 268.4 V_{pp}$.	BII2161MIL, BII2161BNC.	PD = 10mS, D = 10%.

Step 3. **Determine Receiving Bandwidth.** Carrier frequency $f = 35kHz$. Refer to [Input Referred Noise en](#).

To reduce electronic noise, at same time, to avoid affecting 35kHz communication signal, -3dB bandpass filter of receiving can be set to 3.5 to 350 kHz.

Take BII2161BNC and BII7523 FFVS = -197.0 dBV/ μPa as an example, equivalent pressure noise level at input from electronics, approximately:

$P_n = -103.4$ dBV – FFVS of the transducer = 93.6 dB μPa .

Acoustic Project III: 300 kHz Short Distance Underwater Echo Sounding.

Requisites: (1) **Electrical Average Power to NDT Transducer** $P_{avg} = 500 W$, Sine Pulse Duration: 30 μs , D ≤ 0.1%;

(2) Transmit and Receive **Frequency:** 300 kHz.

Transducer Options: 50 Ω Transducer, Z = 50 Ω , 300 kHz.

Step 1. **Signal Types.** Referring to [Typical Signals for Active SONAR...](#) in BII's [Acoustic Transducers and Measurement Handbook](#).

Step 2. Refer to [Max. Transmit Current](#), [Pulse Power Capacity during PD](#) and [Maximum Peak Pulse Voltage as function of Pulse Duration and Duty Cycle](#).

BII2161MIL and BII2161BNC meet limitations above. But BII2161BNC has lower noise level.

Signal Types	Approximately Exciting Voltage to Transducer	TR Switch	PD and D
Sine Pulse (SP) to 50 Ω transducer achieving 500W P_{avg} :	$V_{tx} = \sqrt{8 * P_{avg} * R_{TX}} = 447.2 V_{pp}$.	BII2161MIL. BII2161BNC.	PD = 30 μs ; D ≤ 0.1%.

Step 3. **Determine Receiving Noise Level at input.** Refer to [Input Referred Noise en](#).

-3dB bandpass filter of receiving set to 50 kHz to 1 MHz.

Take BII2161BNC and FFVS of 50 Ω Transducer = -198.0 dBV/ μPa as an example, equivalent pressure noise level at input from electronics, approximately:

$P_n = -99.0$ dBV – FFVS of the transducer = 99.0 dB μPa .

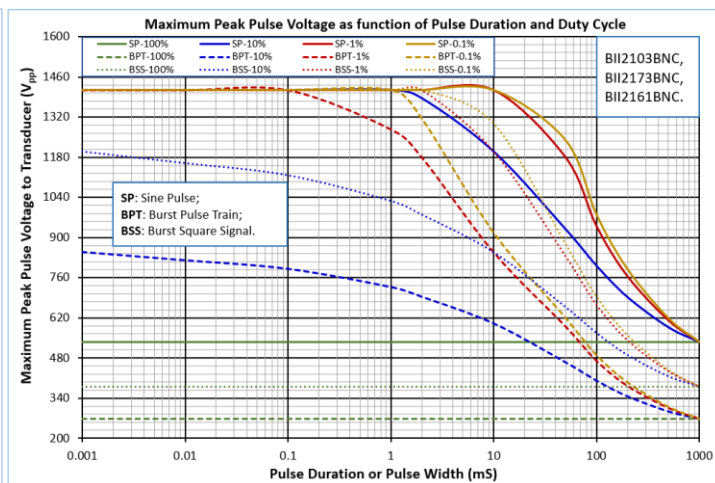
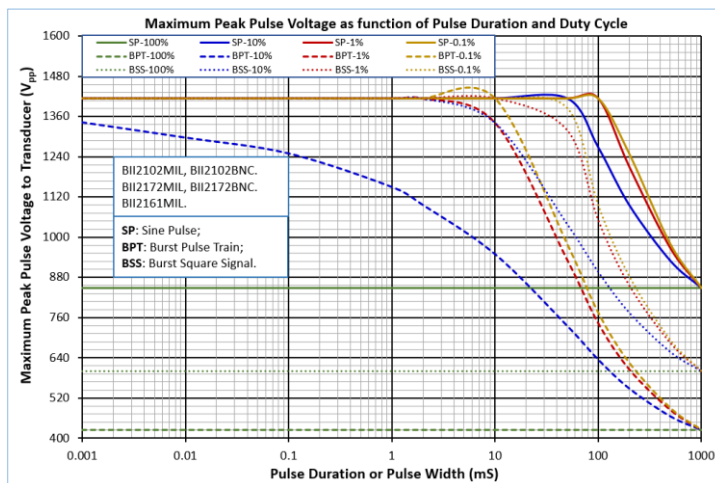
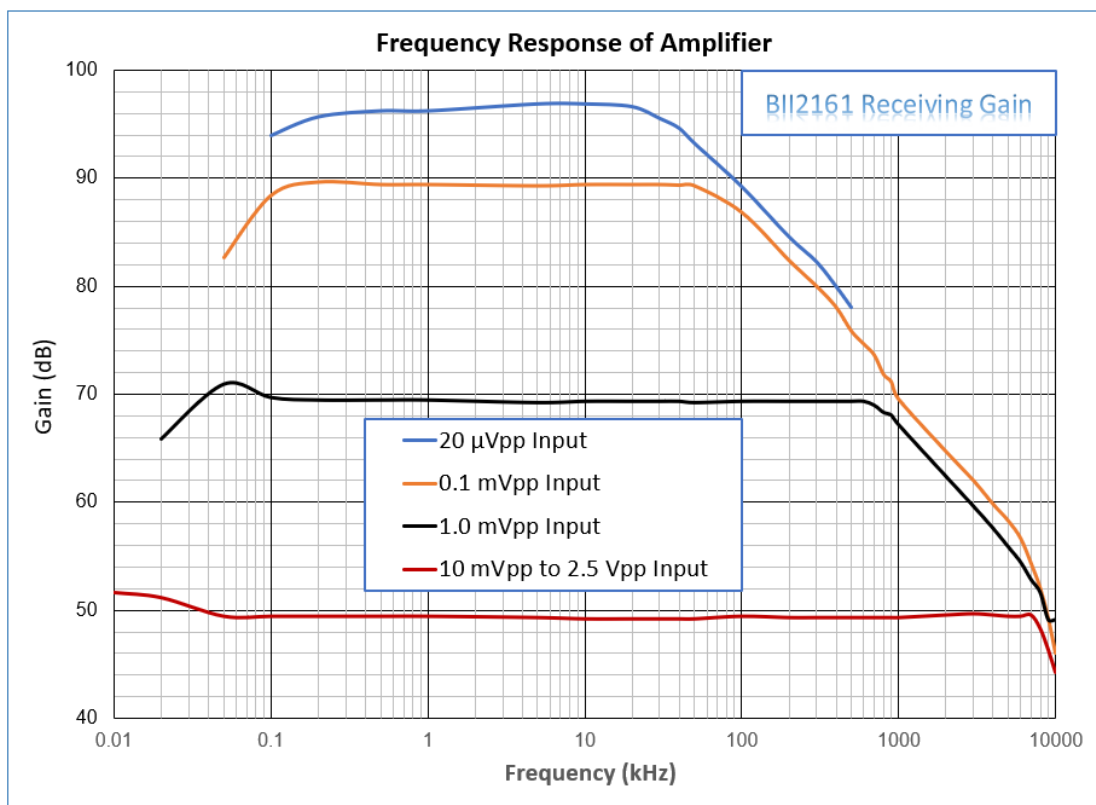
Maximum Peak Pulse Voltage as function of Pulse Duration and Duty Cycle.

Frequency Response of Receiving Gain

Ordering Information of BII2160 Series.

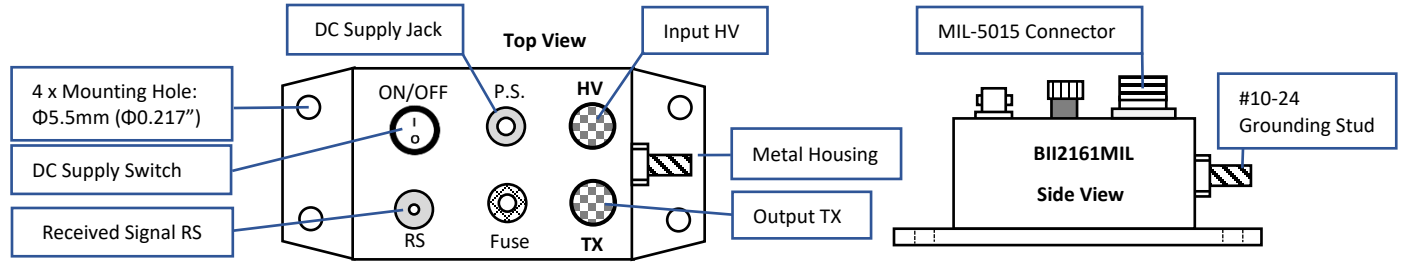
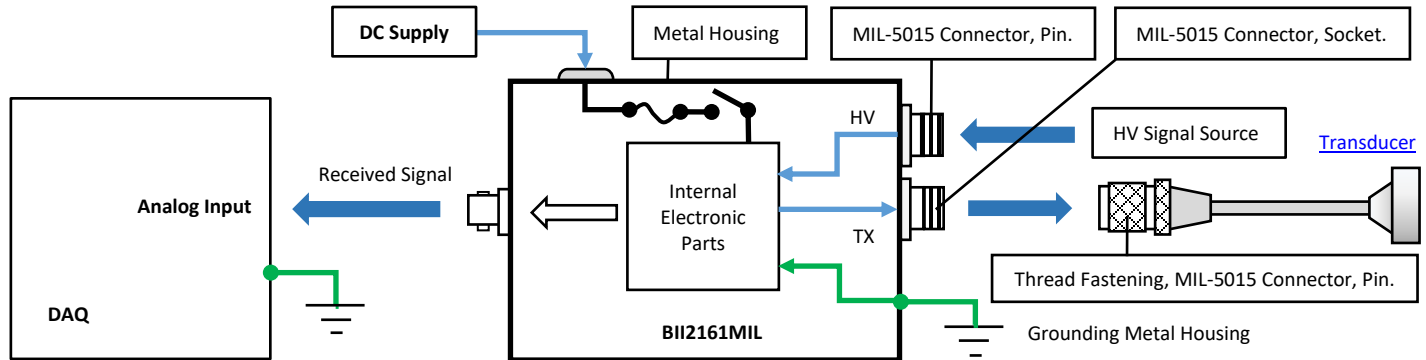
Power: RMS or Peak Power delivered to Transducer from PA, in RMS Watt (Sine/Chirp Pulses, etc.) or Peak Watt (Spike or Single Pulse for NDT). **The POWER can be ignored with blank if RMS power of the transducer and/or the amplifier is known. In these cases, BII will use RMS power of the transducer and/or the amplifier to design the power capacity of the device;** **V_{drive}:** Maximum Driving Voltage to transducer, in Vrms; **PW:** Maximum Pulse Width in μ s, mS, or S; **D:** Maximum Duty Cycle in %; **fs:** Transducer Resonance, in kHz or MHz; **Z_{TX}:** Transducer Impedance at fs, in Ω ; **θ :** Transducer Phase in $^\circ$; **Z_{IM}:** Impedance for Optimum Power Transfer from the PA to the Transducer, in Ω ; **PA:** Power Amplifier; **TX:** Transducer; **PN:** Part Number. **HPF:** -3dB High Pass Filter of Receiving, **LPF:** -3dB Low Pass Filter of Receiving. Refer to [Power Amplifier](#) for available options and wirings. Refer to [Transducer](#) for available options and wirings.

1. BII2161MIL
HV Connector to High Voltage Source: Panel Mount MIL-5015 Pin. **TX Connector to Transducer:** Panel Mount MIL-5015, Socket.

Metal Enclosure, Overall Size = LxWxH = 146.9x91.7x67 mm. Mounting Hole $\Phi 5.5\text{mm}$ ($\Phi 0.217''$) accepts M5 or #10 screw. Screws are not supplied.

System Block Diagram and Wirings

Wirings:

Signals	BII2161MIL		
HV Signals:	MIL-5015 Style Connector, Panel Mount, 3-Contact Mating Connector, Pin.		
	Signal of High Voltage Source	Contact C	
	Signal Common of High Voltage Source	Contact B	
	Shielding and Grounding	Contact A	
TX Signals:	MIL-5015 Style Connector, Panel Mount, MIL-5015, 3-Contact Mating Connector, Socket.		
	Signal of Transducer	Contact C	
	Signal Common of Transducer	Contact B	
	Shielding and Grounding	Contact A	
Received Signal:	Panel Mount BNC Jack.		
	Signal	BNC Center Contact	
	Signal Common, Shielding, Grounding.	Metal Shell Body	
Power Supply:	Panel Mount Power Jack and DC Supply Cable Pair: Part Number DCBP24 .		
	+VDC	Center Contact	Red 4mm Banana Plug
	Signal Common, Shielding, Grounding.	Metal Shell Contact	Black 4mm Banana Plug
DC Supply Switch: Turn ON and Turn OFF DC Supply. "I" -> ON; "O" -> OFF.			
Fuse: One included, refer to Fuse and Holder .			
Accessories: 1. Included: One DC supply cables, Part Number: DCBP24 . 2. Included: One Grounding Cable, Part Number: GWL18 .			
Grounding Metal Case for operating safety. Grounding Stud: #10-24 Screw 316SS. Nut and Washer are included.			
1. Install the device to a safe solid object to avoid sliding. An air free-flowing area and good thermal conducting object allow the device to cool down.			
2. Never use the device in the event of slide happening, otherwise, loss of the device into water, property damage, and person injury may occur.			

How to Order, refer to [Ordering Information of BII2160 Series](#) for explanations of the terms or initials.

	DC Supply Vs:	Transducer Parameter:	Matching Impedance:	Receiving Band Pass Filter:
BII2161MIL	Default. -MV. -HV.	-BII Transducer's Part Number. $-f_s/Z_{TX}/\theta$. $-f_s/R_{TX}$.	-BII PA Part Number. $-Z_{IM}$.	-HPF/LPF Default: $(0.1*f_s)/(10*f_s)$.
Example of Part Number:	Description			
BII2161MIL-HV-BII7506/8-BII5062-0.8kHz/80kHz	BII2161MIL, T/R Switch Module, Bespoke DC Supply Vs: HV, Transducer Parameter: BII7506/8 , Impedance matching to BII5062; -3dB Receiving Band Pass Filter: 0.8 to 80 kHz.			
BII2161MIL-HV-BII7523-50Ω-3.5kHz/350kHz	BII2161MIL, T/R Switch Module, Bespoke DC Supply Vs: HV, Transducer Parameter: BII7523 , Impedance matching to 50Ω; -3dB Receiving Band Pass Filter: 3.5 to 350 kHz.			
BII2161MIL-40kHz/200Ω/-60°-BII5065-5kHz/300kHz	BII2161MIL, T/R Switch Module, Default DC Supply Vs, Transducer Parameter: 40kHz, $Z_{TX}=200\Omega$, $\theta=-60^\circ$, Impedance Matching to BII5065 Power Amplifier ; -3dB Receiving Band Pass Filter: 5 to 300 kHz.			
BII2161MIL-40kHz/60Ω-5Ω-5kHz/300kHz	BII2161MIL, T/R Switch Module, Default DC Supply Vs, Transducer Parameter: 40kHz, $R_{TX}=60\Omega$, Impedance Matching to 5Ω; -3dB Receiving Band Pass Filter: 5 to 300 kHz.			
BII2161MIL-200kHz/50Ω-5Ω-20kHz/1MHz	BII2161MIL, T/R Switch Module, Default DC Supply Vs, Transducer Parameter: 200kHz, $R_{TX}=50\Omega$, Impedance Matching to 5Ω; -3dB Receiving Band Pass Filter: 20 kHz to 1 MHz.			

2. BII2161BNC

HV Connector to High Voltage Source: Panel Mount BNC Jack. **TX Connector to Transducer:** Panel Mount BNC Jack. **BNC Jack Rating: 500Vrms, 316W.**
[Metal Enclosure](#). Overall Size: LxWxH = 146.9x91.7x67 mm. Mounting Hole $\Phi 5.5\text{mm}$ ($\Phi 0.217''$) accepts M5 or #10 screw. Screws are not supplied.

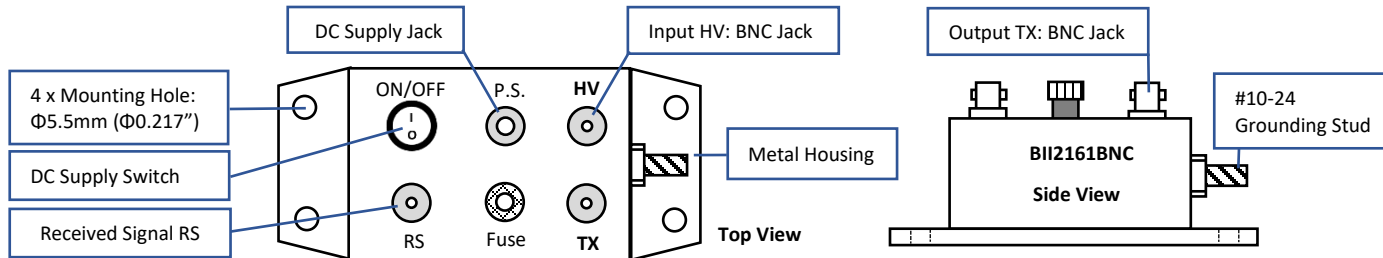
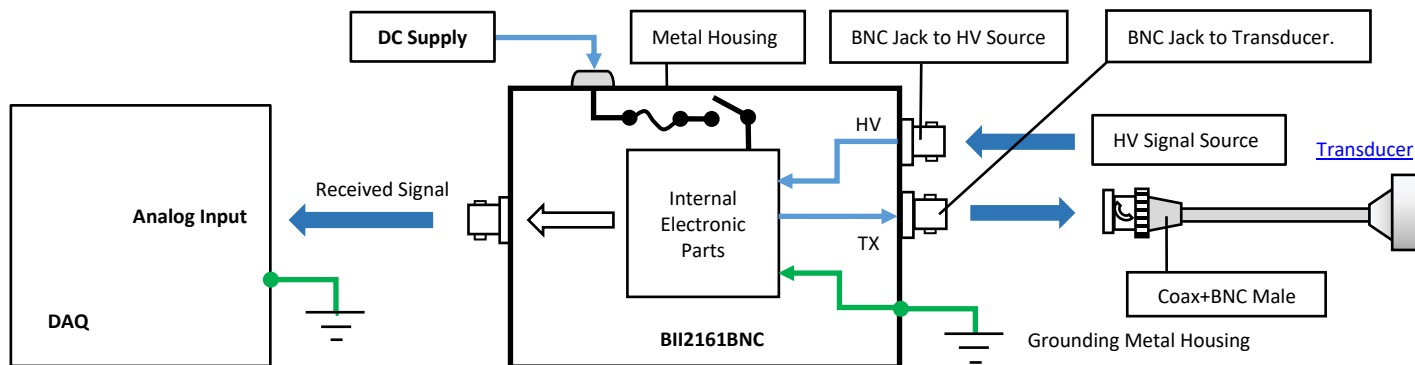
System Block Diagram and Wirings

Wirings:

Signals	BII2161BNC		
HV Signals:	50Ω BNC Connector, Panel Mount, Jack.		
	Signal of High Voltage Source	Center Conductor	
	Signal Common of High Voltage Source	Body Metal Shell	
	Shielding and Grounding	Body Metal Shell	
TX Signals:	50Ω BNC Connector, Panel Mount, Jack.		
	Signal of Transducer	Center Conductor	
	Signal Common of Transducer	Body Metal Shell	
	Shielding and Grounding	Body Metal Shell	
Received Signal:	Panel Mount BNC Jack.		
	Signal	BNC Center Contact	
	Signal Common, Shielding, and Grounding	Metal Shell Body	
Power Supply:	Panel Mount Power Jack and DC Supply Cable Pair: Part Number DCBP24.		
	+VDC	Center Contact	Red 4mm Banana Plug
	Signal Common, Shielding, Grounding.	Metal Shell Contact	Black 4mm Banana Plug
	DC Supply Switch: Turn ON and Turn OFF DC Supply. "I" -> ON; "O" -> OFF.		
Fuse: One included, refer to Fuse and Holder			
Accessories: 1. Included: One DC supply cables, Part Number: DCBP24 . 2. Included: One Grounding Cable, Part Number: GWL18 .			
Grounding Metal Case for operating safety. Grounding Stud: #10-24 Screw 316SS. Nut and Washer are included.			
1. Install the device to a safe solid object to avoid sliding. An air free-flowing area and good thermal conducting object allow the device to cool down.			
2. Never use the device in the event of slide happening, otherwise, loss of the device into water, property damage, and person injury may occur.			

How to Order, refer to [Ordering Information of BII2160 Series](#) for explanations of the terms or initials.

	DC Supply Vs:	Transducer Parameter:	Matching Impedance:	Receiving Band Pass Filter:
BII2161BNC	Default. -MV. -HV.	-BII Transducer's Part Number. $-f_c/Z_{TX}/\theta$. $-f_c/R_{TX}$.	-BII PA Part Number. $-Z_{IM}$.	-HPF/LPF Default: $(0.1*f_c)/(10*f_c)$.
Example of Part Number:		Description		
BII2161BNC-HV-BII7506/8-BII5062-0.8kHz/80kHz		BII2161BNC, T/R Switch Module, Bespoke DC Supply Vs: HV , Transducer Parameter: BII7506/8 , Impedance matching to BII5062; -3dB Receiving Band Pass Filter: 0.8 to 80 kHz.		
BII2161BNC-HV-BII7523-50Ω-3.5kHz/350kHz		BII2161BNC, T/R Switch Module, Bespoke DC Supply Vs: HV , Transducer Parameter: BII7523 , Impedance matching to 50Ω; -3dB Receiving Band Pass Filter: 3.5 to 350 kHz.		
BII2161BNC-40kHz/200Ω/-60°-BII5065-5kHz/300kHz		BII2161BNC, T/R Switch Module, Default DC Supply Vs, Transducer Parameter: 40kHz, $Z_{TX}=200\Omega$, $\theta=-60^\circ$, Impedance Matching to BII5065 Power Amplifier ; -3dB Receiving Band Pass Filter: 5 to 300 kHz.		
BII2161BNC-40kHz/60Ω-5Ω-5kHz/300kHz		BII2161BNC, T/R Switch Module, Default DC Supply Vs, Transducer Parameter: 40kHz, $R_{TX}=60\Omega$, Impedance Matching to 5Ω; -3dB Receiving Band Pass Filter: 5 to 300 kHz.		
BII2161BNC-200kHz/50Ω-5Ω-20kHz/1MHz		BII2161BNC, T/R Switch Module, Default DC Supply Vs, Transducer Parameter: 200kHz, $R_{TX}=50\Omega$, Impedance Matching to 5Ω; -3dB Receiving Band Pass Filter: 20 kHz to 1 MHz.		

Accessories:
1. DC Supply Cable: DCBP24. One 1m DC supply cable with Red and Black Banana Plugs, and DC Power Plug.
To Terminals of DC Supply:

- a. One Red 4mm Banana Plug.
- b. One Black 4mm Banana Plug.

Default 1m. Bespoke Length Available.



 DC Power Plug.
To DC Power Jack
of the Device.

Red Banana Plug: +VDC. **Black Banana Plug:** Common.

One 1m DC supply cable. One end of the cable is with DC Power Plug, another end is Red and Black Banana Plugs. Depending on output terminals of buyer's DC Supply, buyer may assemble other type of connectors to DC supply cable at buyer's cost.

2. Grounding Cable and Terminals
Terminal to buyer's Grounding Terminal:

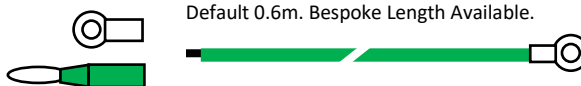
- a. Default: Wire Lead
- b. One #10 Ring Terminal
- c. One 4mm Banana Plug



Default 0.6m. Bespoke Length Available.

 #10 Ring Terminal
#10-24 nut and #10
washer included.

Grounding Cable, Part Number: GWL18, Support Single-Point Grounding with Multiple Devices.

One 0.6m AWG 18 Green Wire (or Green with a Yellow Stripe) with #10 Ring Terminal and Wire Lead. One #10 Ring Terminal and one 4mm Banana Plug (Green) are included. Depending on buyer's grounding terminal type, buyer assembles #10 Ring Terminal, 4mm Banana Plug, or other type of connectors to grounding cable at buyer's cost.

Accessory Cable.
Accessory A9: MIL-UMCF3S, MIL-5015 (3 Pins) to UMC3S (Underwater Connector, 3 Sockets, Locking Sleeve: DLSA-F, Size: Φ 35.5x33.5mm)

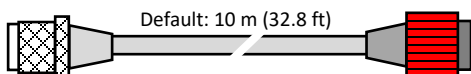
 MIL-5015
3 Pin

Default: 10 m (32.8 ft)

 Underwater Connector, 3 Sockets.
Contact 2: Signal.
Contact 1: Common.
Contact 3: Shielding and Grounding.

 Transducer with 3-Pin Underwater
Connector and DLSA-M Locking Sleeve.

Accessory A10: MIL-SUMC3S, MIL-5015 (3 Pins) to Small UMC3S (Underwater Connector, 3 Sockets, Thread Locking, Size: Φ 22x28mm)

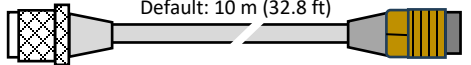
 MIL-5015
3 Pin

Default: 10 m (32.8 ft)

 Underwater Connector, 3 Sockets.
Contact 2: Signal.
Contact 1: Common.
Contact 3: Shielding and Grounding.

 Transducer with 3-Pin Underwater
Connector and MCDLS-F Locking Sleeve.

Accessory A11: MIL-UMCF2S, MIL-5015 (3 Pins) to UMC2S (Underwater Connector, 2 Sockets, Locking Sleeve: DLSA-F, Size: Φ 35.5x33.5mm)

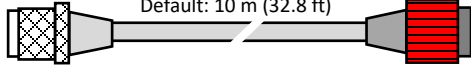
 MIL-5015
3 Pin

Default: 10 m (32.8 ft)

 Underwater Connector, 2 Sockets.
Contact 2: Signal.
Contact 1: Common.

 Transducer with 2-Pin Underwater
Connector and DLSA-M Locking Sleeve.

Accessory A12: MIL-SUMC2S, MIL-5015 (3 Pins) to Small UMC2S (Underwater Connector, 2 Sockets, Thread Locking, Size: Φ 22x28mm)

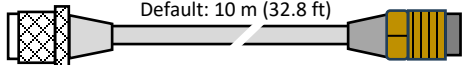
 MIL-5015
3 Pin

Default: 10 m (32.8 ft)

 Underwater Connector, 2 Sockets.
Contact 2: Signal.
Contact 1: Common.

 Transducer with 2-Pin Underwater
Connector and MCDLS-F Locking Sleeve.

Accessory A13: BNC-MIL3S, BNC Male (Pin) to MIL3S (MIL-5015 type 3-Socket Connector Thread Fastening)

BNC Male



0.6 m (2 ft) RG58 Coax

 MIL-5015 Connector, 3 Sockets.
Contact C or G: Signal.
Contact B: Common.
Contact A: Shielding and Grounding.

 Transducer with 3-Pin MIL-5015
Connector.

Accessory A14: BNC-UMCF3S, BNC Male to UMC3S (Underwater Connector, 3 Sockets, Locking Sleeve: DLSA-F, Size: Φ 35.5x33.5mm)

BNC Male

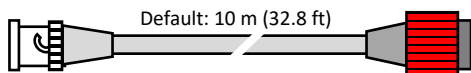

Default: 10 m (32.8 ft)

 Underwater Connector, 3 Sockets.
Contact 2: Signal.
Contact 1: Common.
Contact 3: Shielding and Grounding.

 Transducer with 3-Pin Underwater
Connector and DLSA-M Locking Sleeve.

Accessory A15: BNC-SUMC3S, BNC Male to Small UMC3S (Underwater Connector, 3 Sockets, Thread Locking, Size: Φ 22x28mm)

BNC Male

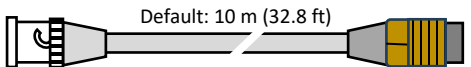

Default: 10 m (32.8 ft)

 Underwater Connector, 3 Sockets.
Contact 2: Signal.
Contact 1: Common.
Contact 3: Shielding and Grounding.

 Transducer with 3Pin Underwater
Connector and MCDLS-F Locking Sleeve.

Accessory A16: BNC-UMCF2S, BNC Male to UMC2S (Underwater Connector, 2 Sockets, Locking Sleeve: DLSA-F, Size: $\Phi 35.5 \times 33.5$ mm)

BNC Male

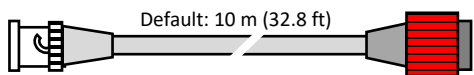

Underwater Connector, 2 Sockets.
Contact 2: Signal.
Contact 1: Common.



Transducer with 2-Pin Underwater Connector and DLSA-M Locking Sleeve.

Accessory A17: BNC-SUMC2S, BNC Male to Small UMC2S (Underwater Connector, 2 Sockets, Thread Locking, Size: $\Phi 22 \times 28$ mm)

BNC Male

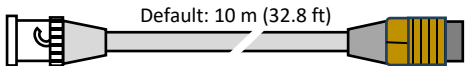

Underwater Connector, 2 Sockets.
Contact 2: Signal.
Contact 1: Common.



Transducer with 2-Pin Underwater Connector and MCDLS-F Locking Sleeve.

Metal Housings, Outline Dimensions (mm), Illustration only, the scale is not 1:1.

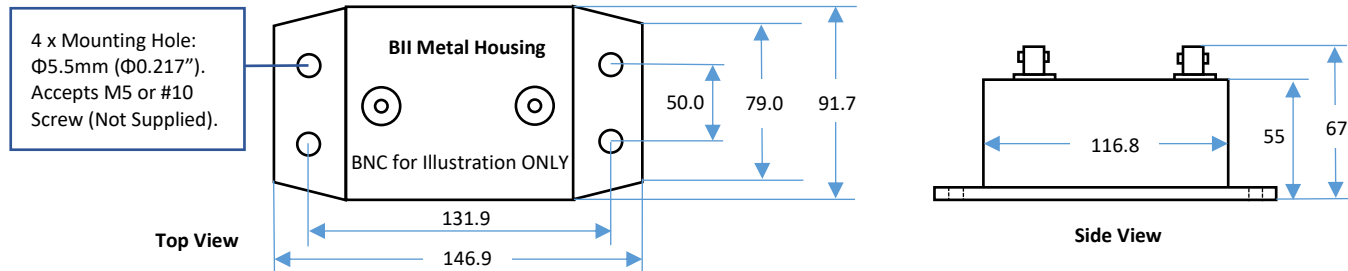

Preamplifier Wirings to DAQ (Data Acquisition Hardware): DAQ: Data Acquisition Hardware; AI: Analog Input; CH: Channel; GND: Ground.

BII's Single-Ended Output to Single-Ended Input of a DAQ

BII's Single-Ended Output to Differential Input of a DAQ

If input impedance of a DAQ device is greater than $100\text{M}\Omega$, use following wiring with one $100\text{k}\Omega$ to $1\text{M}\Omega$ resistor.

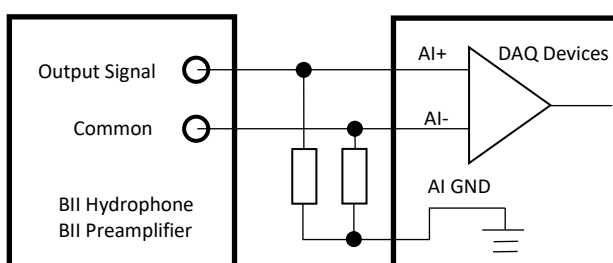
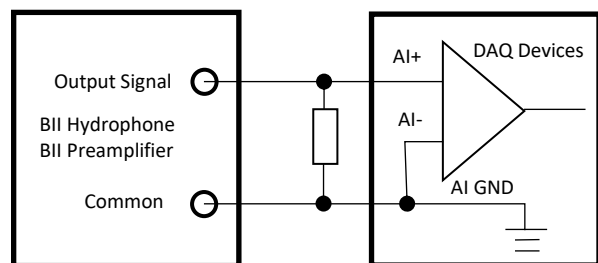

Questions

How do I assemble #10 Ring Terminal or 4mm Banana Plug to Grounding Cable?

- for #10 Ring Terminal, crimp or solder is acceptable. Please choose a suitable crimp tool for crimping connector and cable, or a suitable solder station for soldering.
- for 4mm Banana Plug, solder is acceptable. Please choose a suitable solder station for soldering.

What if the connector of my transducer/sensor is SMA or SMC Connector?

Buyer may order a SMA (or SMC) to BNC (Male) adaptor from local electronic distributors in buyer's country. BII may ship the adaptor as accessory of the device. Please specify this request when ordering. **By default, BII does NOT supply the adaptor as accessories.**

What if connectors of my transducers and/or power amplifiers are NOT MIL-5015 type connectors?

The custom-made adaptors are recommended such as MIL-5015 to BNC, MIL-5015 to Underwater connectors, MIL-5015 to XLR, etc. BII can manufacture these adaptors which bridge your devices and BII devices. Please discuss with BII for customizations.

Frequencies of my pingers (transponder, or beacon) range from 20 kHz to 300 kHz, what are the gains of a BII AGC to amplify or attenuate the signals automatically?

Gain of a BII AGC varies from -20 dB to 100 dB to amplify or attenuate input signal of 100 Hz to 200 kHz.

Gain of a BII AGC varies from -20 dB to 80 dB to amplify or attenuate input signal of 200 kHz to 2 MHz.

How do I wire BII devices to audio connectors (XLR or TRS) of my recording devices?

BII devices has panel-mount TRS or BNC jack as output connector. The custom-made adaptors are recommended such as BNC to XLR, BNC to TRS, etc. BII can manufacture these adaptors which bridge your devices and BII devices. Please discuss with BII for customizations.