



BII7180 Series Miniature Probe Hydrophone and AE Sensor: Ø1.0 to Ø3.0mm Aperture

BII7180 Series Miniature Probe Hydrophone and NDT/AE Sensor

Underwater Sounds: BII7180 series are miniature hydrophones with small aperture size and usable up to 3 MHz. Conical and omnidirectional directivity patterns are available. Multiple miniature probe hydrophones can be configured as a vector hydrophone (vector sensor) or array for uses in extraction of directional information (source location), measurement of particle velocity, particle acceleration and pressure gradient.

The probe hydrophones are practical and handy tools for research and application of Helmholtz Integral Equation in underwater acoustics and for the measurement of pressure or intensity distribution of near-field and far-field radiated from vibrational and acoustical sound sources underwater.

NDT in Solids: receiving audible and ultrasonic sounds, acoustic emission (AE), structural health monitoring (SHM), metallurgical properties of metals, etc... The couplant such as water or gel is a must-have material to provide efficient acoustic coupling between the receiving face of the hydrophone and the piece under test (the subject). The hydrophones can be glued on or inside subject permanently with adhesives such as epoxy.

NDT in Fluids: uses in waterlike and airlike fluids for the analysis of their macroscopic and microscopic, physical and chemical properties.

BII7180 series should not be used with flammable and/or explosive materials, and not used in Solvents such as hydrochloric acid, isopropyl alcohol, ethyl lactate, acetone, xylene, Iso hexanes, mineral spirits, etc...

Technical Notes:

Particle Velocity in x direction $u_x = -1/(j\omega\rho)(\partial p/\partial x)$; ρ : Density; $\partial p/\partial x$: Pressure Gradient in the x direction.

Dipole Vector Hydrophone: Voltage Response $V=M*(d/\lambda)*\cos\theta$; M: Amplitude Constant related to element sensitivity; d: spacing distance between two elements; θ : Arriving angle from the axis of the two elements.

$$\text{Helmholtz Integral: } p(\vec{r}) = \frac{1}{4\pi} \iint \left[\frac{e^{-jkR}}{R} j\omega\rho u(\vec{r}_0) + p(\vec{r}_0) \frac{\partial}{\partial n_0} \left(\frac{e^{-jkR}}{R} \right) \right] dS_0$$

Typical Applications

Study of Acoustic Radiation Field	General Purpose Hydrophone, Reference Hydrophone, Near-field Calibration.
Ultrasonic Testing and Analysis, Thermoacoustic Tomography.	Acoustic Emission (AE), Non-Destructive Test (NDT), Structural Health Monitoring (SHM).
Helmholtz Integral in Acoustics, Boundary Element Acoustics.	Trouble-shooting, Maintenance and Development of Transducers and Array.
Vector Hydrophones/Array Elements.	High Sound Level Measurement (Warning: Cavitation will damage hydrophone)

Underwater Sound Listening, Recording, and Communication

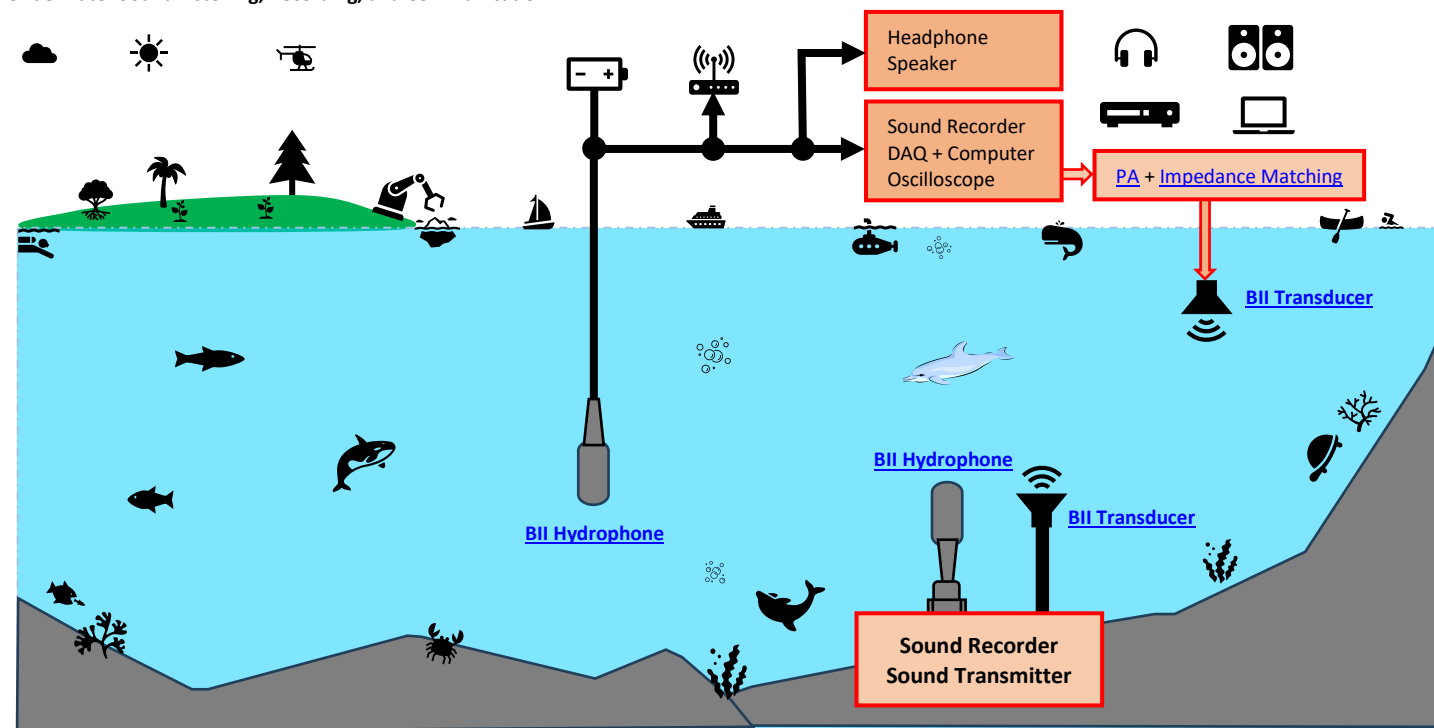

Typical Applications

Underwater Sounds Recording, Listening, and Communication, Noise Measurement, Marine Bioacoustics, Passive Acoustic Monitoring (PAM System).
Coastal/Offshore Processes, Engineering & Management, Wave-Structure Interaction, Wave-height Sensor, Wave and Tide Recorder/Logger.
Surface Waves, Ocean Turbulences, Hydrodynamics, Marine Geophysics, Battery-Powered Instruments: Sonobuoy, Recorder, Transponder, Acoustic Release...

Questions

How do I set up my professional sound recorders to work with BII Hydrophones?

1. BII hydrophones have their own DC power supply to support Line Input of recorders, and Do NOT use phantom power 48V which may destroy the hydrophones.
2. Maximum Input Level (Line Input) of recorders should be large enough to avoid saturation or clipping during recording.

Equivalent Input Noise of recorders should be low enough for the recorders to be sensitive to weak signal of the interest.

3. Sampling Rate of the recorder should be fast enough to avoid missing high frequency sound of the interest. Generally, the Sampling Rate should be at least two times greater than the maximum frequency of sound.
4. Calculate the memory size of data storage according to sampling rate, resolution, sampling channels, and recording time, and use suitable recording media.
5. Calculate battery service life according to battery power and consuming current.
6. When the cable is greater than 5m, balanced signal or differential signal is recommended to be in use over the cable.

How do I playback the recorded sounds in water?

System Setup: Recorder (Recorded Sounds) with Line or Phone Output -> [Audio Power Amplifiers](#) -> [Impedance Matching Device](#) -> [Transducers \(Projectors\)](#).

System Configuration of Receiving Sounds and Waves.

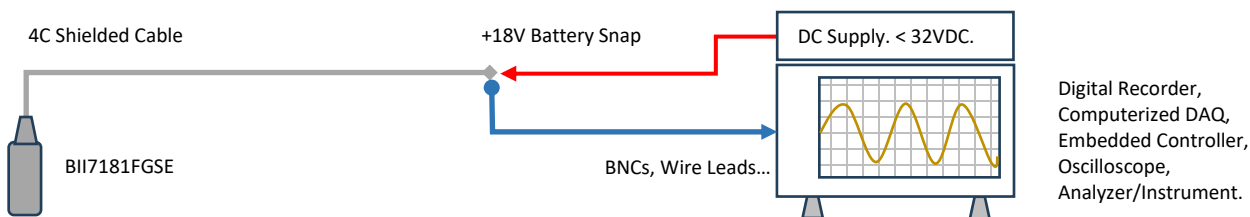

Installation to Underwater Submersibles:

Thru-hole Mounting, End-face Mounting, Flush Mounting, Underwater Connector, etc.

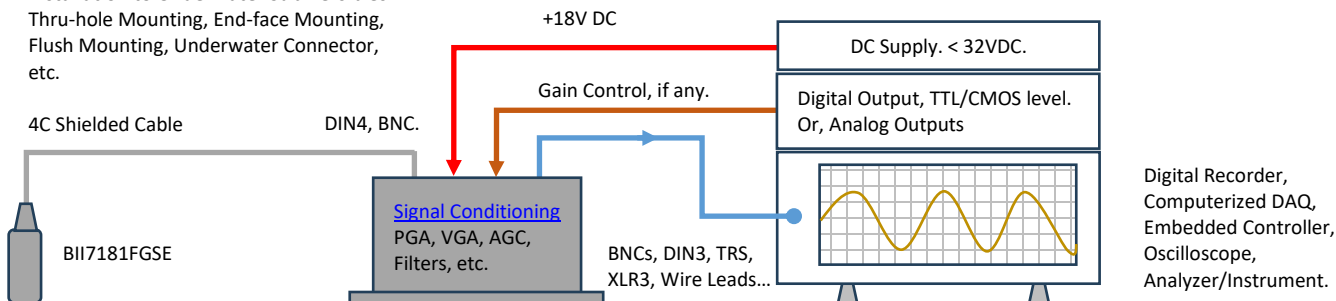

“Figure 8” Pattern of a Dipole (Pressure-Gradient).

Cardioid Pattern= Omnidirectional + Dipole.

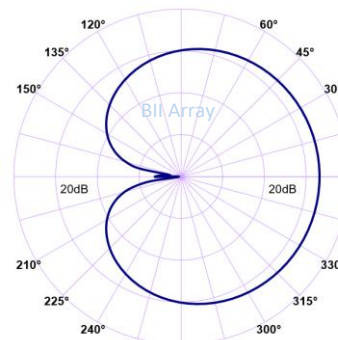
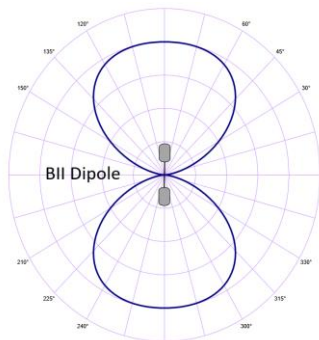
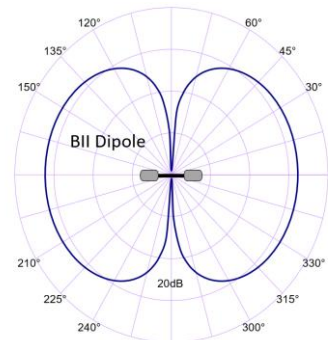

Specification

The hydrophone is tested in water unless stated otherwise.	
FG: Fixed Gain; PG: Programmable Gain; DF: Differential Output; SE: Single Ended Output; BPF: Band Pass Filter; HPF: High Pass Filter; LPF: Low Pass Filter.	
Part Number:	BII7181FGSE
Sensitivity @ 1 kHz:	-221.5 + Preamp Gain, ± 2 dB V/ μ Pa. -181.5 dB V/ μ Pa.
Sensitivity Matching: (at 1 kHz)	When hydrophones are used as array elements, it is necessary for array elements to possess uniform sensitivities. Available Options of Sensitivity Tolerance: a. ± 2.0 (Default); b. ± 1.0 ; c. ± 0.5 in dB V/ μ Pa. 1. Sensitivity is tested at 1 kHz in water. 2. Hydrophones whose sensitivity variations are out of specified tolerance are rejected.
FFVS:	Refer to Graph of FFVS vs. Frequency . Free-field Voltage Sensitivity.
Pressure Noise Density:	Refer to Graph of Pressure Noise Density , Referred to Input (RTI), in μ Pa/ \sqrt Hz.
Built-in Filters:	Bespoke HPF or BPF. Minimum high pass filter $f_{-3dB} = 14$ Hz.
	in Water: 14 Hz ~ 1 MHz.
	in Air: 14 Hz ~ 20 kHz.
	1. Reduce Noise. Both ocean ambient noises and the self-noises of electronic devices decrease when frequency increases and/or narrower bandwidth. It is recommended to choose a built-in high pass filter to reject noises in low frequency range and narrow the bandwidth. For example, if you are interested in the signals greater than 100kHz, you may specify a high pass filter with -3dB cut-off frequency at 10kHz to improve signal to noise ratio of the signals of the interest. 2. Avoid Saturation. When there are strong low frequency noises, disturbances, and/or vibrations, resulting from rough surface waves and/or mechanical movements of the platform, it is recommended to specify a high pass filter to avoid hydrophone saturation in these low frequency ranges.

Preamp Gain (dB):	Built-in, Fixed Gain Preamp: 40 dB Gain.
Signal Conditioning:	If your project need extra signal conditioning before data acquisition, please refer to signal conditioning , and order separately. Options: Programmable Gain Amplifier PGA, Variable Gain Amplifier (VGA), Automatic Gain Control (AGC) Amplifier, and Amplifiers with Built-in, High-pass, Low-pass, and Band-pass Filters. Packages: Standalone Devices for portable uses, and Coated PCB with Wire Bundles for underwater submersibles.
Receiving Face:	Cylindrical Face
Directivity Pattern:	Omnidirectional and Toroidal. Refer to Graph of Directivity Pattern
Side Lobes:	No side lobes.
Signal Output Type:	Single Ended.
Maximum Output V_{omax} :	Supply Voltage V_s - 4, in Vpp.
Overload Pressure Level:	$20 \cdot \log(V_{omax}/2.828)$ - Sensitivity, in dB μ Pa, whichever is less. Refer to the chart of Overload Pressure Level (OPL) .
Acceleration Sensitivity:	124.6 dB μ Pa/(m/s ²) at Acoustic Axis . ≤ 115 dB μ Pa/(m/s ²) at other directions .
Operating Depth:	Maximum 300 m or 3 MPa pressure and limited by the cable length if the cable has wire leads or a non-waterproof connector.
Mounting Options:	1. Default: Free Hanging (FH). 2. Free-hanging with Male Underwater Connector (FHUWC-4P). 3. Thru-hole Mounting with Single O-ring (THM-M10 , THM-7/16" , or THM-5/8"). 4. Thru-hole Mounting with Double O-ring (THDO-7/16"). 5. Bolt Fastening Mounting (Plastics) (BFMP-NPT3/8"). 6. Bolt Fastening Mounting (Stainless Steel) (BFM-7/16" , BFM-5/8"). 7. Thread Mounting with Single O-Ring (TMSO-M10x15 , TMSO-M10x22). Please refer to online document AcousticSystem.pdf for a complete list of Mounting Options and more details.
Cable Options:	1. Default: Four Conductor Shielded Cable (SC) 2. Bespoke: Cable Bundle (CB) for 50 Ω Cabling: 2-Conductor shielded cable for DC supply and 50 Ω RG174 or RG58 Coax for signal.
Cable Orientation:	Perpendicular to end face of hydrophone.
Cable Length:	Default: 10m (32.8ft) for Non-Underwater Connector; 0.6m (2ft) for Underwater Connectors. Refer to Maximum Cable Length . The chart is based on 5Vpp Sinusoidal signals. Maximum cable length which a hydrophone can drive is proportional to output voltage level of the hydrophone. To avoid signal distortion over long cable in MHz range, 50 Ω coax wiring should be considered when cable length is greater than 30m and useful signals are in MHz range.
Connector:	1. Default: Wire Leads (WL). 2. Male BNC (BNC) (Max. Diameter Φ 14.3 mm). 3. DIN Receptacle with 4 Male Pins (DIN4), (Max. Diameter Φ 17 mm). 4. Underwater Mateable Connector UMC4P , made by global manufacturers, buyer may search online to get detailed specs of these connectors from their manufacturers. Available in-stock options (the customized is available upon request): 4 pins (UMC4P = MCIL4M + MCDLS-F , or MCOM4M + OMBMC + MCDLS-F), Maximum Diameter Φ 21.5 to Φ 35 mm. 5. +9VDC Battery Snaps (BS), for +18VDC power supply. 6. 4mm Banana Plug Pair (Red and Black Color) (BP), for DC power supply ONLY. Underwater Mateable Connectors are for underwater uses. Other connectors/wire leads are for dry uses and are not waterproofed.
BNC: "Bayonet Neill–Concelman" is a miniature quick connect/disconnect radio/audio frequency connector used for coaxial cable. Fastening Type: Bayonet Lock. DIN: Electrical cylindrical connectors, 3 to 14 contacts, Φ 20mm diameter, used for audio, RF, digital, and DC or AC power signals. Fastening Type: Threaded. UMC: Underwater Mateable Connectors, interconnection solution for high power or weak signals. Fastening Type: Threaded. Underwater Uses.	
Supply Voltage V_s :	+9 to +30 VDC. Warning: The device will be destroyed with $V_s \geq +32$VDC.
Suggested DC Supply:	+9VDC Battery, Marine Battery, Automobile Battery, Fixed DC Linear Power Supply, Not Included. DO NOT use variable power supply whose maximum supply voltage is higher than the rated voltage. DO NOT use switching mode DC power supply.
Current (Quiescent):	Refer to Quiescent Current IQ .
Size:	Sensing Element and Support: Φ DxL= Φ 6.2x22mm and Φ 16.4x17mm; Preamp Housing: Φ DxL= Φ 21x50 mm. Varies with options. Other Mounting Types: actual length depends on Mounting Parts.
Weight:	0.76 kg with 20m cable. Actual weight depends on Mounting Parts, Cable Types and Length.
Operation Temperature:	-10 °C to +60 °C or 14 °F to 140 °F.
Storage Temperature:	-20 °C to +60 °C or -4 °F to 140 °F.
Sound Measurement in Air: The hydrophones can be used to detect sounds in air. The sensitivity in air is same to the one in water in low frequency range.	

How to Order Standard Hydrophones. BII Keeps Standard Products in Stock.

FG: Fixed Gain; SE: Single-ended Output; BPF: Band Pass Filter; HPF: High Pass Filter; LPF: Low Pass Filter.					
Part Number	-HPF/LPF	-Mounting	-Shielded Cable Length	-Cable Type	-Connectors for Signal/DC Supply
BII7181FGSE	14 Hz ~ 1 MHz	FH: Free Hanging.	10 m (32.8 ft)	SC	WL, BNC, BS.
In-Stock Examples:		Description			
BII7181FGSE-14Hz/1MHz-FH-10m-SC-WL		BII7181FGSE Hydrophone, Bandpass Filter: 14Hz to 1MHz, Free Hanging, 10m Shielded Cable, Connector: None, Wire leads.			
BII7181FGSE-14Hz/1MHz-FH-10m-SC-BNC/BS		BII7181FGSE Hydrophone, Bandpass Filter: 14Hz to 1MHz, Free Hanging, 10m Shielded Cable, Connector: BNC for Signal, 9V Battery Snaps for DC Supply.			
Non-stock Examples:		Description			
BII7181FGSE-1kHz/1MHz-FH-10m-SC-DIN4		BII7181FGSE Hydrophone, Bandpass Filter: 1kHz to 1MHz, Free Hanging, 10m Shielded Cable, Connector for Signal and DC Supply: DIN4.			
BII7181FGSE-1kHz/1MHz-BFM-5/8"-30m-CB-BNC/WL		BII7181FGSE Hydrophone, Bandpass Filter: 1kHz to 1MHz, Bolt Fastening Mount: BFM-5/8", 30m Cable Bundle (2C SC Cable + RG58 Coax), BNC for Signal and Wire Leads for DC Supply.			
BII7181FGSE-10kHz-FHUWC-4P		BII7181FGSE Hydrophone, High Pass Filter: 10kHz, Free-hanging with Male Underwater Connector FHUWC-4P.			

Wiring Information of Hydrophones with Fixed-gain Preamps:

Single-ended Output:	Wire Leads	UMC4P, FHUWC-4P.	BNC + Two 9V Battery Snaps	BNC + Wire Leads	DIN4
+VDC	Red	Pin 3	Battery Female Snap	Red	Pin 4
Common	Black	Pin 1	Battery Male Snap	Black	Pin 1
Signal	White	Pin 2	BNC Center	BNC Center	Pin 3
Signal Common	Blue, Green, or Yellow	Pin 4	BNC Metal Shell	BNC Metal Shell	Pin 2
Shielding	Cable Shield	N/A	BNC Metal Shell	BNC Metal Shell	Metal Shell

Free-field Voltage Response (FFVS):

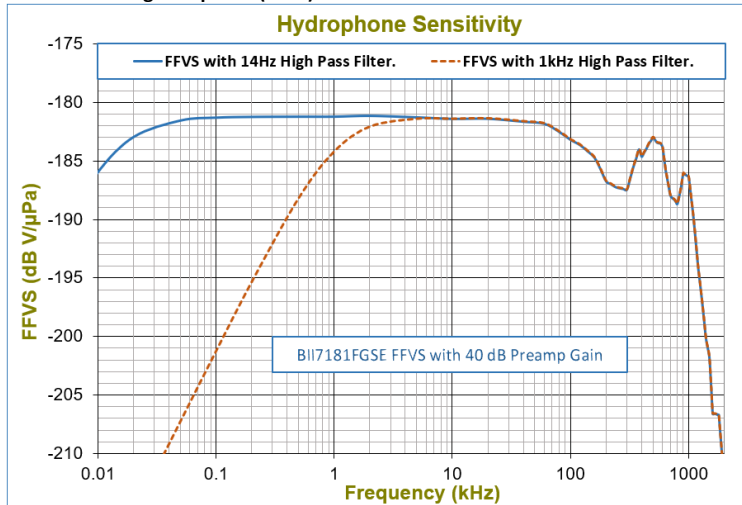

Pressure Noise Density (RTI, referred to the input):

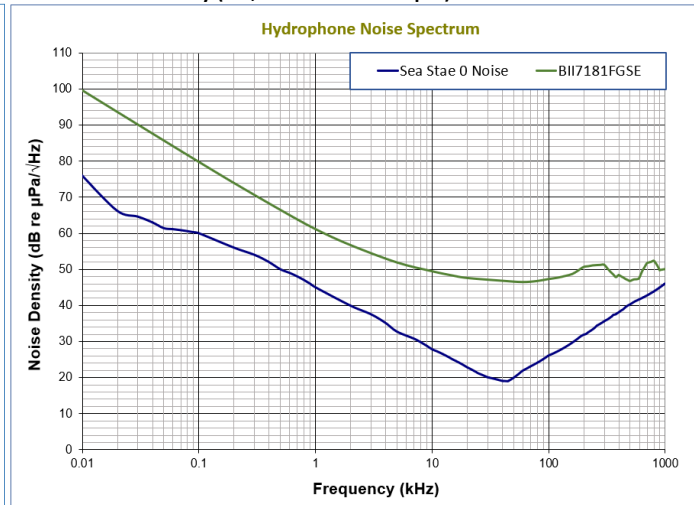

Overload Pressure Level (OPL) and Quiescent Current IQ

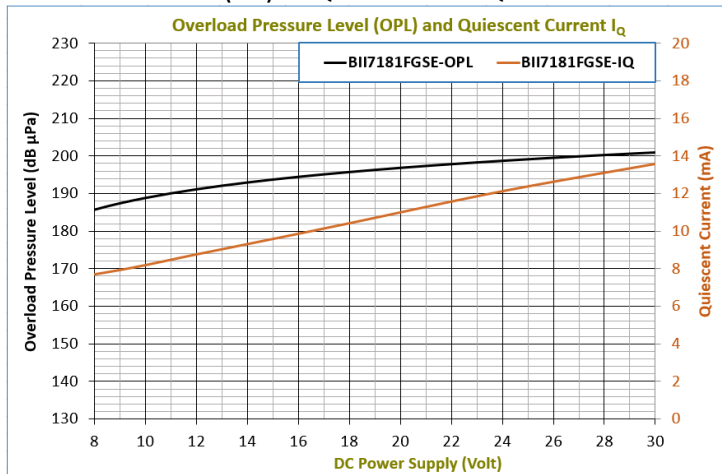

Maximum Cable Length

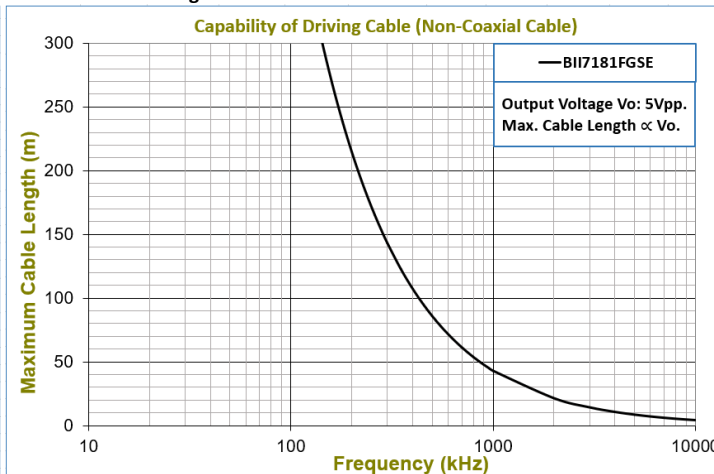

Directivity Pattern

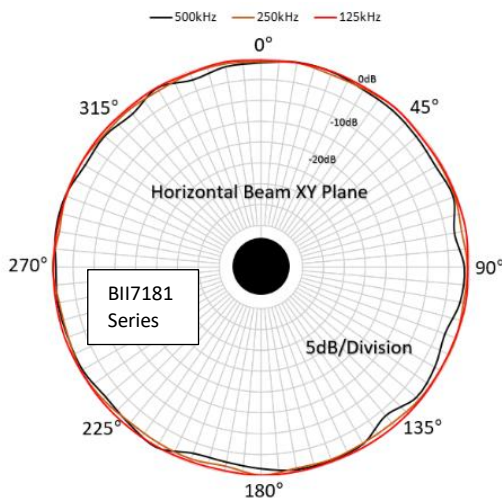
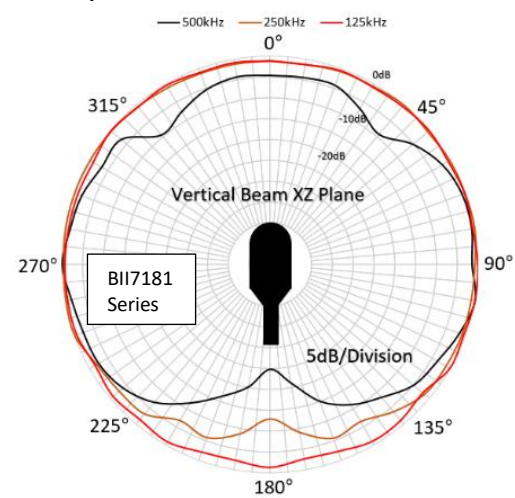

Physical Size (Dimension Unit: mm): The overall length varies with the length of the built-in preamplifier and mounting parts.

1. Free Hanging.

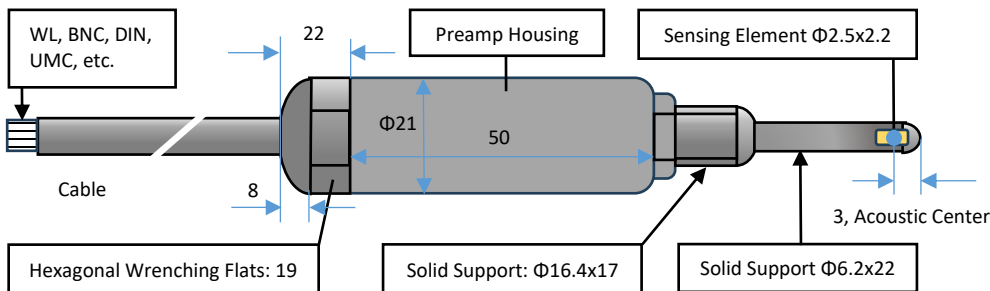

The hydrophone body has streamlined hemispherical domes which minimize the drag forces and the hydrodynamic noise caused by the hydrophone in motion or the flow past the hydrophone.

Customization of Length Reduction of the Hydrophone: Hydrophone can be made as "L" shape with solid support perpendicular (90°) to the housing wall. Appending "L" to the part number (BII7181FGSE-L) when ordering to specify L-shaped Hydrophone.

2. Bolt-Fastening Mounting BFMP-NPT3/8", 3/8" NPT Thread Length: 15mm. Nut Height: 5mm. **Tips: Plastic material has less sound reflection.**

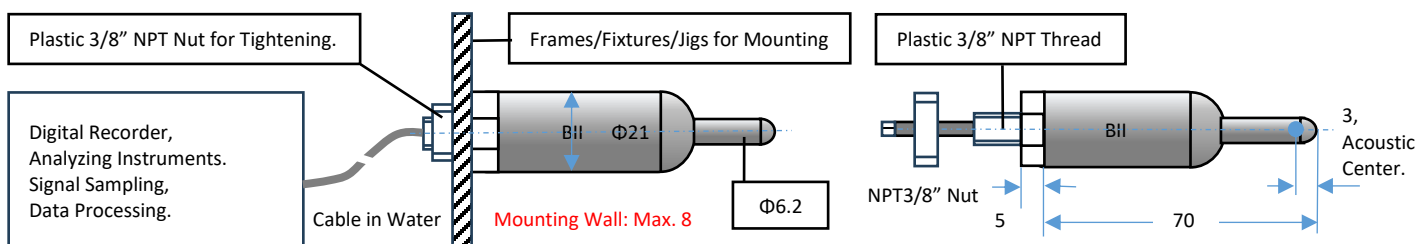

3. Bolt-Fastening Mounting BFM-7/16" (7/16"-20x22 UNF-2A), and BFM-5/8" (5/8"-18x22 UNF-2A, **BFM-5/8" does NOT possess Hexagonal Wrenching Flats.**)

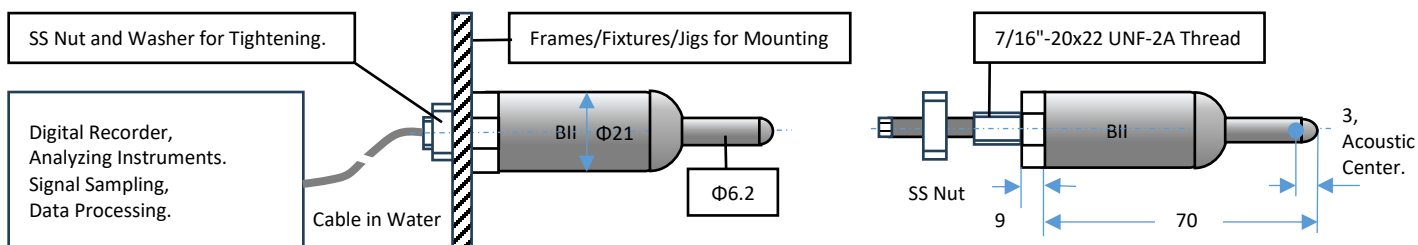

4. Thru-hole Mounting (Inch Thread) with Single O-ring Sealing THM-7/16" (7/16"-20x22 UNF-2A), and THM-5/8" (5/8"-18x22 UNF-2A, **does NOT possess Hexagonal Wrenching Flats.**)

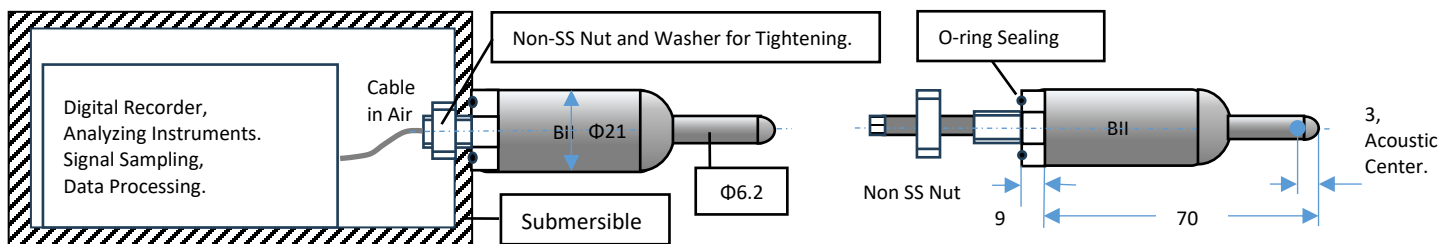

5. Free-hanging with Underwater Connector FHUWC-4P, 4 Pins (Fixed Sensitivity); FHUWC-6P, 6 Pins (Programmable Sensitivity).

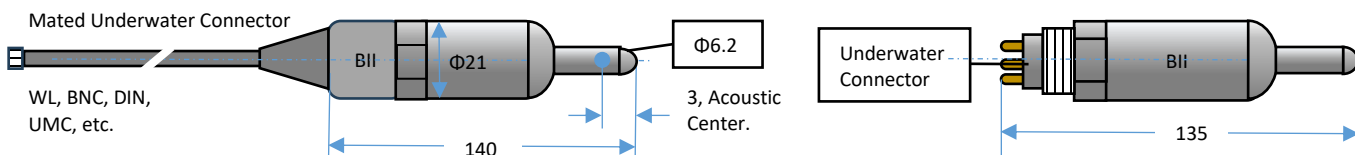

6. More Mounting/Installation Options: Please refer to online document [AcousticSystem.pdf](#) for a complete list of Mounting Options and details.