



BII7500 Series High Power Piston Transducer: Low Frequency

BII's piston transducers are made from Tonpilz (Langevin, Sandwich, Transmission Line) elements with features of high power, medium Qm, and low frequency. Custom-fit array can be set up with multiple transducers in field to increase sound level and achieve narrow beam. *These transducers are NOT suitable for echo sounding applications because of the long ringing.*

TYPICAL APPLICATIONS

Array Element: Parametric, Linear, Planar & Cylindrical Array. Seabed Penetration/Sediment Profiler/Sub-bottom Profiling. Artificial Acoustic Target, Echo-Repeater. Direction-finding Sonar/Multi-beam Sonar.	Pinger/Locator/Transponder/Positioning/Tracking. Underwater Communication and Telephone. Bioacoustics, Marine Animal Behavior Research, Bioacoustic Stimuli. High Acoustic Energy Sources, Acoustic Deterrent to Marine Animals.
---	---

SYSTEM CONFIGURATION of Transmitting Sounds.

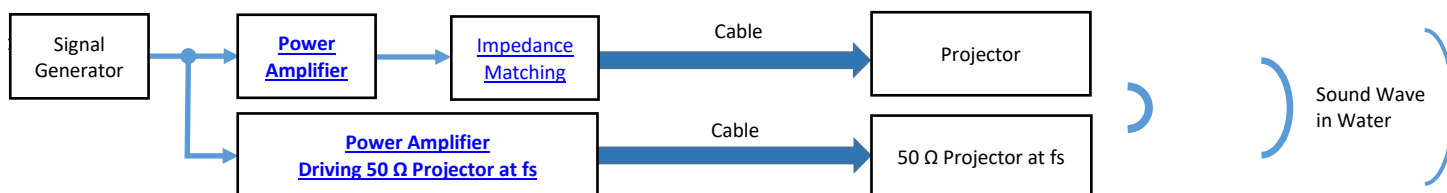

RELATED PRODUCTS

Power Amplifier for SONAR, NDT, and HIFU	Impedance Matching between Transducers and Amplifiers
--	---

Linear (Rectangular) Array Beam Steering

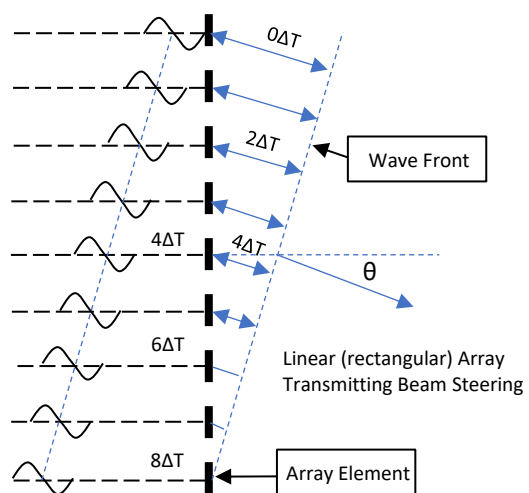

Linear, Annular, and Planar Array Beam Focusing

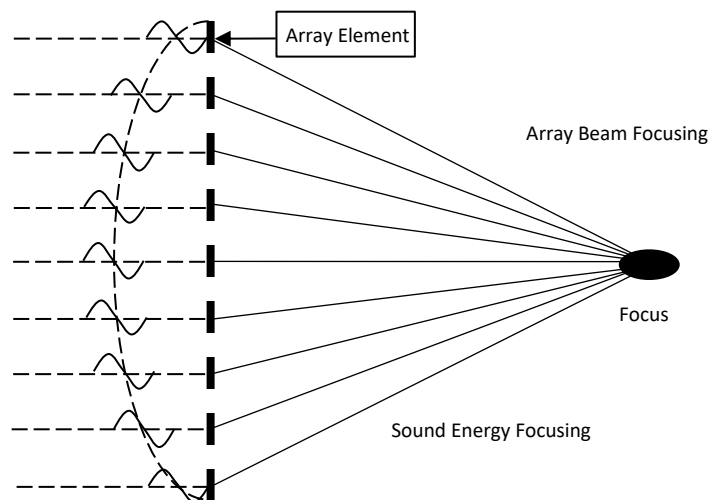

Simple Array Consisting of Piston Transducers as Array Elements (Directional Planar Elements), **Illustration ONLY.**

Linear Phased Array of Discrete Elements: Beam Steering

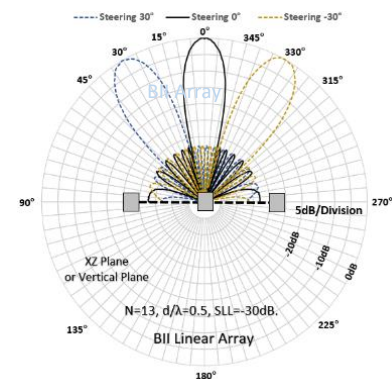

Circular Planar Array of Discrete Elements: Amplitude Shading

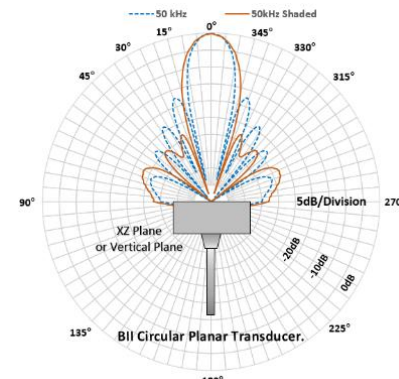

TRANSDUCER SPECIFICATIONS
SPECIFICATIONS

Transducer:	BII7502/28	BII7502/28-IM50Ω
Major Applications:	1. Generate powerful acoustic waves in water and solid. 2. BII recommends the transducers not to be used as low noise broadband acoustic receivers such as Hydrophone, AE, NDT Receiver, etc. Please refer to BII Hydrophone for standalone low noise broadband acoustical receivers.	
Resonant Frequency f_s :	28 kHz, $\pm 10\%$.	28 kHz, $\pm 10\%$.
Transmitting Frequency:	$f_s \pm 20\% * f_s$	$f_s \pm 25\% * f_s$
	Minimum Transmitting Frequency: None.	Minimum Transmitting Frequency $f_{min} = 10$ kHz.
	Warning: if Operating Frequency < f_{min}, transducer impedance is very low which causes over-current issue to power amplifier, and results in overheat issue (damage) to power amplifier and the transducer.	
Impedance Matching:	No	Built-in, Impedance matching to 50Ω by default.
Signal Type:	SINE Pulses, Chirp, PSK, FSK, Pulsed Square Waveform, Continuous Signals, Arbitrary Signals, etc.	
	SONAR/Communication/Pulsing Signals, Aquatic/Marine Animal Sounds, Ambient and Ship/Vehicle Noises, etc.	
Directivity Pattern:	Conical Beam at f_s . Refer to Graph of Directivity Pattern . Omnidirectional at $f \leq f_{omni}$ or Omnidirectional at $f \ll f_s$.	
f_{omni} :	5 kHz.	
-3dB Beam Width:	66° at 28 kHz	
Side Lobe Level:	No Sidelobes.	
Free Capacitance C_f :	4.3 nF $\pm 10\%$ @ 1 kHz	N/A
	With cable, C_f increases by (Cable Length * 0.1nF/meter).	
Dissipation D:	0.003 @ 1 kHz	N/A
Quality Factor Q_m at f_s :	9.0	8.0
	-3dB bandwidth $\Delta f = f_s/Q_m$. Q_m determines the transient response or the rise and fall rings of steady-state response.	
η_{ea} at f_s in Water:	0.67, Electroacoustic Efficiency.	0.67
η_{ea} at $f \ll f_s$:	at $f \ll f_s$, $\eta_{ea} / \eta_{ea \text{ at } f_s} \approx 0.1225 * (k * \Phi D)^2$. Wave Number $k = 2\pi/\lambda$; ΦD = Transducer Diameter.	
	1. Electroacoustic Efficiency η_{ea} is quite low at $f \ll f_s$ and drops gradually at $f > f_s$, so it is NOT recommended for transducers to emit high power sounds at frequencies far from f_s . Otherwise, transducer may be damaged by overheating. 2. Transducer can emit low power sounds at frequencies far from f_s . For example, input power $P_i \leq \eta_{ea} * MIPP$ at $f \leq 0.8 * f_s$ and $P_i \leq 0.2 * MIPP$ at $f \geq 1.3 * f_s$.	
Power Factor at f_s :	0.68	≥ 0.95
TVR at f_s :	Refer to TVR Chart , Transmitting Voltage Response. Tolerance: ± 2 dB.	
	148.0 ± 2 dB $\mu Pa/V@1m$.	162.0 ± 2 dB $\mu Pa/V@1m$ for BII7502/28-IM50Ω. 172.0 ± 2 dB $\mu Pa/V@1m$ for BII7502/28-IM5Ω.
Radiation Sound Level SL:	SL = 20*log V_i + TVR, dB $\mu Pa@1m$. Driving Voltage V_i is in unit of V_{rms} .	
Admittance or Impedance:	Refer to G-B Chart .	1. Default: $Z = 50 * e^{i\theta}$, in Ω , and Phase Angle $ \theta \leq 20^\circ$ at f_s . 2. Customization: refer to Impedance Matching at f_s .
Driving Voltage V_i at f_s : (V_{imax} : Maximum V_i)	Pulsed Driving Signal and Duty Cycle D < 100%: $V_{imax} = \sqrt{(MIPP/G_{max})}$ or 600 , whichever is less, in V_{rms} .	Pulsed Driving Signal and Duty Cycle D < 100%: $V_{imax} = \sqrt{(MIPP * Z)}$, in V_{rms} . Z is impedance at f_s .
	Continuous Operation at 100% Duty Cycle: $V_{imax} = \sqrt{(MCIP/G_{max})}$, in V_{rms} .	Continuous Operation at 100% Duty Cycle: $V_{imax} = \sqrt{(MCIP * Z)}$, in V_{rms} .
	To achieve higher sound level, built-in impedance matching is recommended to step up driving voltage inside the transducer.	
Input Power P_i :	$P_i = V_i^2 * G$. Refer to G-B Graph : G is conductance.	$P_i = V_i^2 / Z$ at f_s . Z is impedance at f_s , or 50Ω by default.
MIPP at f_s :	$V_i^2 * G_{max}$ or 140 Watts, whichever is less.	140 Watts.
MPW at MIPP and f_s :	600 Seconds.	
MCIP at f_s :	140 Watts.	
MIPP: Maximum Input Pulse Power. MPW: Maximum Pulse Width. MCIP: Maximum Continuous Input Power. f_s : Resonance Frequency. G_{max} is maximum G at f_s .		
How to determine pulse width, duty cycle and off-time with input pulse power (peak power) at f_s:		
1. Determine the input pulse power (IPP, peak power) with sound intensity required by the project. IPP MUST be less than MIPP.		
2. Pulse Width $\leq (MIPP * MPW * (120^\circ C - T) / 103^\circ C) / IPP$. T: Water Temperature in $^\circ C$.		
3. Duty Cycle $D \leq MCIP * (120^\circ C - T) / 103^\circ C / IPP$.		
4. Off-time $\geq PW * (1 - D) / D$.		
FFVS at f_s :	-176.0 ± 2 dB V/ μPa .	-190.0 ± 2 dB V/ μPa for BII7502/28-IM50Ω. -200.0 ± 2 dB V/ μPa for BII7502/28-IM5Ω.
	$Sensitivity \text{ Loss over extension cable at } f_s \text{ (dB)} = 20 * \log \{ (1 + 2\pi f_s C_c / B) / \sqrt{[G^2 + (B + 2\pi f_s C_c)^2] / (G^2 + B^2)} \}$ G: Conductance at f_s ; B: Susceptance at f_s ; C_c: Capacitance of Extension Cable. Cable is of 100 pF/meter roughly. FFVS: Free-field Voltage Sensitivity. Please refer to online document AcousticSystem.pdf for conversion between G-B and Z- θ , if necessary.	
	Sensitivity Loss over Extension Cable (dB) = 20*log $[C_h / (C_h + C_c)]$. Valid for hydrophone without preamplifier. C_h: Hydrophone Capacitance; C_c: Capacitance of Extension Cable. Cable is of 100 pF/meter roughly.	
Receiving Sound Level SL:	SL = 20*log V_o - FFVS, dB μPa . Receiving Voltage V_o is in unit of V_{rms} .	
Receiving Frequency:	1 Hz to 1.5* f_s .	$f_s \pm 25\% * f_s$
Operating Depth:	Maximum, 300 m or 3 MPa Pressure.	
	Limited by the cable length if the cable has wire leads or a non-waterproof connector.	
Mounting Options:	1. Default: Free Hanging (FH) 2. Thru-hole Mounting with Single O-ring (THM-M10, THM-7/16" , or THM-5/8" .) 3. Thru-hole Mounting with Double O-ring (THDO-7/16") 4. Bolt Fastening Mounting (Stainless Steel) (BFM-7/16" , or BFM-5/8" .) 5. Bolt-Fastening Mounting with Free Hanging (BFMFH-3/8" .) 7. Free-hanging with Male Underwater Connector (FHUWC-2P , or FHUWC-3P .)	

	8. End-face Mounting (EFMS , or EFMM .) 9. Flange Mounting (FGM-Φ110 .) Please refer to online document AcousticSystem.pdf for a complete list of Mounting Options and more details.	
Cable Options:	1. Shielded Cable (SC), Rubber or PVC Jacket. 2. 50 Ω RG58 Coax (RG58). 3. Shielded Cable with Twisted Pair and Teflon (PTFE) Jacket, ΦD=4.0 mm (SC40), up to 200°C, AWG20 Conductors (Not Water-proofed, ONLY for Dry Air Use). 4. Two Conductor Unshielded Cable (USC) for Underwater Connector 2 Pins or 3 Pins. Handling: Do not use the cable to support transducer weight in air and water if the transducer has a mounting part. Do not bend the cable.	
Cable Length:	1. Default: 15 m with non-underwater connector. 0.6m with Underwater Mateable Connector (2 pins) (UMC2P). 2. Custom-fit.	
Connector:	1. Default: Wire Leads (WL), for Transmit, Receive Signal, and DC Power Supply. 2. Underwater Mateable Connector (2 pins) (UMC2P) (Max. Diameter Φ21.5 to Φ35 mm). Locking Sleeve: DLSA-M. Underwater Mateable Connector (3 pins) (UMC3P) (Max. Diameter Φ21.5 to Φ35 mm). Locking Sleeve: DLSA-M. Underwater Mateable Connectors are fixed with 0.6m unshielded cable. UMC is from global manufacturers of underwater connectors. Its part number is listed in quote in detail. 3. MIL-5015 Style (3 pin) (MIL3P) (Max. Diameter Φ19 to Φ30 mm). 4. XLR Receptacle with 3 Male Pins (XLR3P), (Max. Diameter Φ20.2 mm), for SE or DF. 5. DIN Receptacle with 3 Male Pins (DIN3P), (Max. Diameter Φ17 mm), for SE or DF. 6. Male BNC (BNC) (Max. Diameter Φ14.3 mm), for Transmit or Receive Grounded Signal. Note: Underwater Mateable Connector is for uses underwater. Other connectors and wire leads are for dry uses and are not waterproofed.	
Physical Size:	ΦD xH = Φ60 x 95 mm	ΦD xH = Φ60 x 150 mm
	Actual length depends on Mounting Parts and/or Add-on Parts such as -TR, -IM, etc.	
Weight in Air:	≥ 1.5 kg with 15 m cable.	≥ 2 kg with 15 m cable.
	Actual weight depends on Mounting Parts, Cable Types and Length, and/or Add-on Parts such as -TR, -IM, etc.	
Operation Temperature:	-10 °C to +60 °C or 14 °F to 140 °F.	
Storage Temperature:	-20 °C to +60 °C or -4 °F to 140 °F.	
Impedance Matching at f_s :	BII6000 Bespoke Impedance Matching between transducers and power amplifiers. Order Separately as standalone devices or append -IMxxΩ to the part number for integrating BII6000 into the transducer and specify impedance in Ω at f_s . For example, BII7502/28-IM5Ω: BII7502/28 transducer with built-in Impedance Matching unit as 5Ω load at f_s . Phase Angle $ \theta $ of Complex Impedance $\leq 20^\circ$ at f_s .	
TR Switch Module:	None. This transducer is NOT recommended to be used in Echo-sounding.	
Power Amplifier:	BII5000 Power Amplifiers for SONAR, NDT, HIFU. Order Separately as standalone devices.	
WARNING: DANGER — HIGH VOLTAGE on wires. Wires shall be insulated for safety. DO NOT TOUCH THE WIRES BEFORE THE DRIVING SIGNAL IS SHUT DOWN. Cable shield must be grounded firmly for safety. for 50Ω BNC connector, it is buyer's sole responsibility to make sure that the BNC shield of the signal source is firmly grounded for operating safety before hooking up transducer/hydrophone to the signal source. Coax with BNC is not intended for hand-held use at voltages above 30Vac/60Vdc.		

System Block Diagram of Generate Sounds

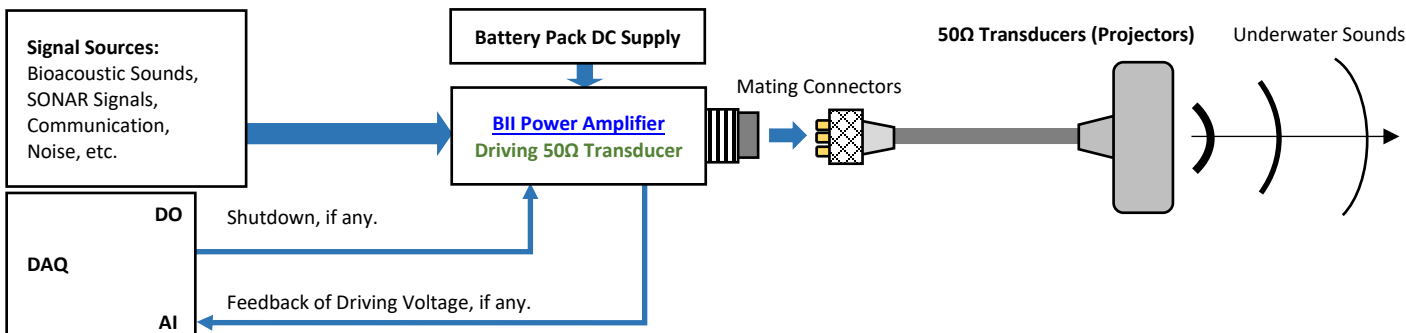

Wiring Information of a Transducer without T/R Switch.

Transducer Wiring:	Shielded Cable	Coax, BNC.	UMC3P, Locking Sleeve: DLSA-M.	MIL3P	DIN3P	XLR3P
Signal:	White or Red	Center Contact	Contact 2	Contact C or G	Pin 3	Pin 2
Signal Common:	Black	Shield	Contact 1	Contact B	Pin 1	Pin 3
Shielding and Grounding	Shield	Shield	Contact 3	Contact A	Pin 2	Pin 1
Wiring of Unshielded Cable:	Wire Leads WL	UMC2P (0.6m USC Cable originally coming from manufacturer of the connector, Fixed.). Locking Sleeve: DLSA-M.				
Signal	White	Contact 2				
Signal Common	Black	Contact 1				

How to Order Transducers. The default options are for stock items which are regularly available.

FH: Free Hanging. SC for Transmit: Shielded Cable (Rubber Jacket, 600V) with 2 conductors. Coax: 50 Ω Coaxial Cable. WL: Wire Leads.
Underwater Mateable Connector UMC2P is fixed with 0.6m unshielded cable (USC).

Part Number	-Appendage	-Mounting	-Cable Length	-Cable Type	-Connector for signals of Transmit
BII7502/28	Default: IM50Ω	Default: BFMFH-3/8"	Default: 15m or 0.6m.	SC for low frequency signal. USC for UMC2P Connector.	Default: WL.
Example:		Description			
BII7502/28-BFMFH-3/8"-15m-SC-WL		BII7502/28 Transducer, Bolt-Fastening Mounting with Free Hanging: BFMFH-3/8", 15m Shielded Cable, Wire Leads.			
BII7502/28-BFMFH-3/8"-0.6m-USC-UMC2P		BII7502/28 Transducer, Bolt Fastening Mounting with Free Hanging: BFMFH-3/8", 0.6m Unshielded Cable, Male Underwater Mateable Connector with Locking Sleeve: DLSA-M.			
BII7502/28-IM50Ω-FH-20m-RG58-BNC		BII7502/28 Transducer, Built-in Impedance Matching Network as 50Ω load at fs, Free Hanging, 20m RG58 Coax, Male BNC.			
BII7502/28-IM8Ω-FH-15m-SC-XLR3P		BII7502/28 Transducer, Built-in Impedance Matching Network as 8Ω load at fs, Free Hanging, 15m Shielded Cable, XLR Plug.			

Transmitting Voltage Response

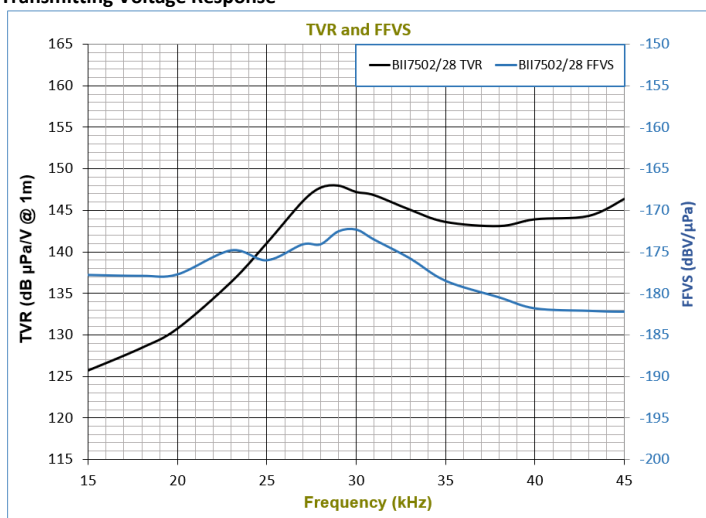

Beam Pattern

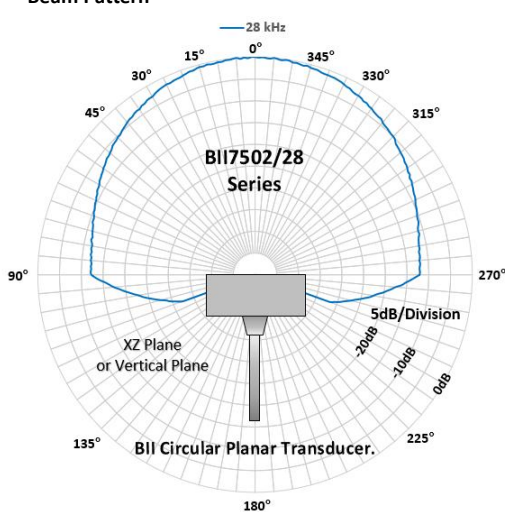

Admittance and Impedance

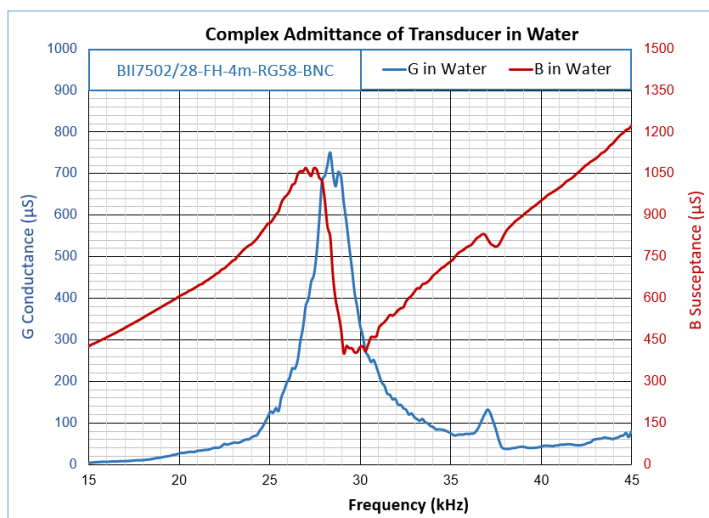

Physical Size (Dimensional Unit: mm)

1. Cable-out Layout for Bolt Fastening Mount with Free Hanging Cable ([BFMFH-3/8"](#)).

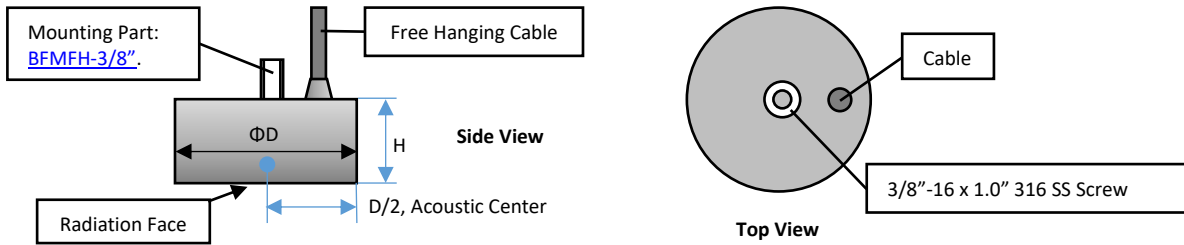

2. Bolt-Fastening Mounting BFM-7/16" (7/16"-20x22 UNF-2A) for Small Transducer, or BFM-5/8" (5/8"-18x22 UNF) for Large Transducer.

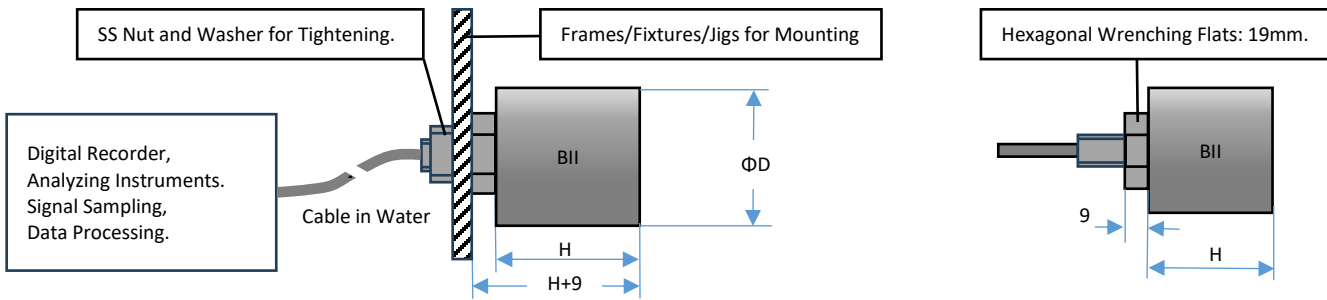

3. Thru-hole Mounting with Single O-ring Sealing THM-7/16" (7/16"-20x22 UNF-2A) for Small Transducer, or THM-5/8" (5/8"-18x22 UNF) for Large Transducer.

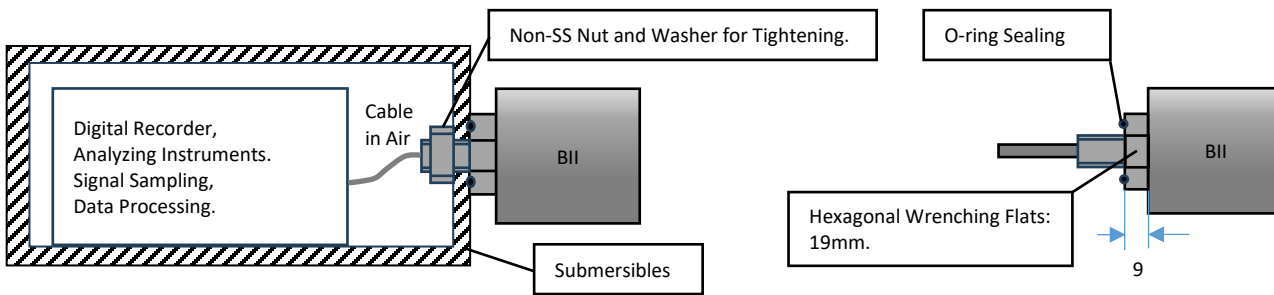

4. Free-hanging with Underwater Connector (FHUWC-3P), 3 Pins.

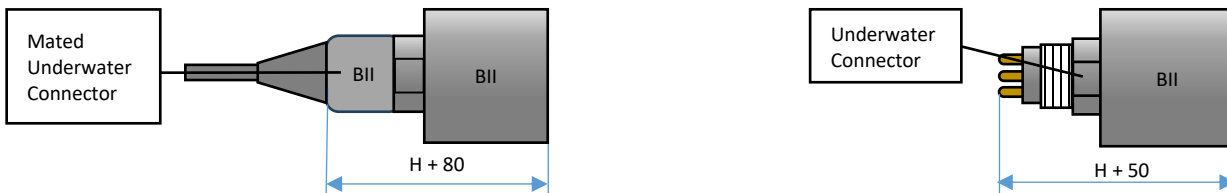

6. More Mounting/Installation Options: Please refer to online document [AcousticSystem.pdf](#) for a complete list of Mounting Options and details.

Question:

What if the mating connector of my DAQ module or recording device is NOT available from BII?

1. Buyer may order BII products with wire leads, and buyer assembles the mating connector to the cable end.
2. A connector adaptor might be assembled by BII by customization, and BII ships the adaptor to buyer as accessory of the device. Please contact BII for customizations.
3. Many adaptors for standard connectors are available in worldwide electronic suppliers such as BNC to SMA, BNC to SMC, XLR to TRS, etc. Check out your local suppliers.

What are the advantage and disadvantage of a built-in T/R Switch Module comparing to a standalone T/R Switch Module?

A built-in T/R Switch Module amplifies the received signal of the sensing element before received signal is polluted by EMI noises and system ground loop noises, and before the received signal is attenuated by impedance matching network (if any), and capacitance, inductance, and resistance of cables. But its price is a little bit higher than standalone T/R Switch Module.

What are the features of the transducer when operating $f \ll f_s$ (f_s is resonance frequency)?

1. Roughly, the TVR drops at 6dB/Octave or 20dB/Decade.
2. Power factor drops to be half per octave or one tenth per decade.
3. Efficiency drops with frequency decreasing. More and more electrical energy is consumed by transducer to be converted to heat which damage the transducer when the temperature inside transducer is over 100°C to 120°C (212°F to 248°F) roughly. Therefore, (1) when a transducer operates at $f \ll f_s$, the driving power from power amplifier MUST be low enough to avoid damage. (2) Use a low frequency transducer whose f_s is at or very close to the frequencies of the interest.